

STONEGATE

COMMUNITY DEVELOPMENT DISTRICT

February 6, 2024

BOARD OF SUPERVISORS REGULAR MEETING AGENDA

STONEGATE
COMMUNITY DEVELOPMENT DISTRICT

AGENDA
LETTER

Stonegate Community Development District
OFFICE OF THE DISTRICT MANAGER
2300 Glades Road, Suite 410W•Boca Raton, Florida 33431
Phone: (561) 571-0010•Fax: (561) 571-0013•Toll-Free: (877) 276-0889

January 30, 2024

Board of Supervisors
Stonegate Community Development District

<p><u>ATTENDEES:</u> Please identify yourself each time you speak to facilitate accurate transcription of meeting minutes.</p>

Dear Board Members:

The Board of Supervisors of the Stonegate Community Development District will hold a Regular Meeting on February 6, 2024 at 6:30 p.m., at the Malibu Bay Clubhouse, 1020 NE 34th Avenue, Homestead, Florida 33033. The agenda is as follows:

1. Call to Order/Roll Call
2. Public Comments: *non-agenda items*
3. Consideration of Bid Response to RFP Regarding Malibu Bay Clubhouse Pool Deck and Swimming Pool Equipment Improvements
4. Discussion: Allstate Resource Management Lake 4 Inspection Report
5. Consideration of Resolution 2024-01, Implementing Section 190.006(3), Florida Statutes, and Requesting that the Miami-Dade County Supervisor of Elections begin Conducting the District's General Elections; Providing for Compensation; Setting Forth the Terms of Office; Authorizing Notice of the Qualifying Period; and Providing for Severability and an Effective Date
6. Consideration of Resolution 2024-02, Providing for the Appointment of a Records Management Liaison Officer; Providing the Duties of the Records Management Liaison Officer; Adopting a Records Retention Policy; Determining the Electronic Record to be the Official Record; Providing for Severability; and Providing for an Effective Date
7. Consideration of Resolution 2024-03, Establishing an Electronic Signature Policy, Providing District Manager with Authority and Responsibility for Approval of Electronic Signatures and Implementation of Control Processes and Procedures to Ensure Compliance, Integrity, and Security, in Accordance with Chapter 688, Florida Statutes; and Providing for Severability and Effective Date
8. Ratification of Miami-Dade County Polling Place Agreement

9. Consent Agenda Items

- A. Acceptance of Unaudited Financial Statements as of December 31, 2023
- B. Approval of September 13, 2023 Public Hearings and Regular Meeting Minutes

10. Staff Reports

- A. Operations Manager: *UNUS Property Management*
- B. District Counsel: *Billing, Cochran, Lyles, Mauro & Ramsey, P.A.*
 - Required Ethics Training
- C. District Engineer: *Alvarez Engineers, Inc.*
- D. District Manager: *Wrathell, Hunt and Associates, LLC*
 - NEXT MEETING DATE: March 5, 2024 at 6:30 PM

○ QUORUM CHECK

SEAT 1	ALBERTO EIRAS	<input type="checkbox"/> IN PERSON	<input type="checkbox"/> PHONE	<input type="checkbox"/> NO
SEAT 2	JOE MCGUINNESS	<input type="checkbox"/> IN PERSON	<input type="checkbox"/> PHONE	<input type="checkbox"/> NO
SEAT 3	YONIEL BOZA	<input type="checkbox"/> IN PERSON	<input type="checkbox"/> PHONE	<input type="checkbox"/> NO
SEAT 4	ART GOESSEL	<input type="checkbox"/> IN PERSON	<input type="checkbox"/> PHONE	<input type="checkbox"/> NO
SEAT 5	MARIELA FIGUEROA	<input type="checkbox"/> IN PERSON	<input type="checkbox"/> PHONE	<input type="checkbox"/> NO

11. Supervisors' Requests

12. Adjournment

Should you have any questions, please do not hesitate to contact me directly at (561) 909-7930.

Sincerely,



Daniel Rom
District Manager

FOR BOARD MEMBERS AND STAFF TO ATTEND BY TELEPHONE:

CALL-IN NUMBER: 1-888-354-0094

PARTICIPANT PASSCODE: 528 064 2804

STONEGATE
COMMUNITY DEVELOPMENT DISTRICT

3

BID ANALYSIS AND ALLOCATION OF FUNDS SOURCE						
Contractor →				Rock Power Paving Corp.		
PAY ITEM NO.	ITEM	UNIT	TOTAL QUANTITIES	TOTAL	UNIT PRICE	TOTAL PRICE
POOL PROJECT (OTHER SOURCE OF FUNDS)						
1	Diamond Brite Plaster for Pool	EA	1	1.0	\$ 82,500.00	\$ 82,500.00
2	Pool Cartridge Filter for Pool	EA	1	1.0	\$ 12,600.00	\$ 12,600.00
3	Pool Pump Equipment	EA	1	1.0	\$ 12,596.85	\$ 12,596.85
4	Collector Tank for Pool	EA	1	1.0	\$ 25,110.00	\$ 25,110.00
5	Chemical Feeder Pumps for Pool	EA	1	1.0	\$ 4,200.00	\$ 4,200.00
6	Flowmeter for Pool	EA	1	1.0	\$ 807.69	\$ 807.69
7	Diamond Brite Plaster for Wading Pool	EA	1	1.0	\$ 3,750.00	\$ 3,750.00
8	Collector Tank for Wading Pool	EA	1	1.0	\$ 5,370.00	\$ 5,370.00
9	Pool Cartridge Filter for Wading Pool	EA	1	1.0	\$ 2,625.00	\$ 2,625.00
10	Pool Equipment for Wading Pool	EA	1	1.0	\$ 2,055.00	\$ 2,055.00
11	Flowmeter for Wading Pool	EA	1	1.0	\$ 328.13	\$ 328.13
12	Vats for Chemicals	EA	1	1.0	\$ 2,053.80	\$ 2,053.80
13	Chemical Feeder Pumps for Wading Pool	EA	1	1.0	\$ 3,281.25	\$ 3,281.25
14	Backflow Preventor	EA	1	1.0	\$ 5,196.19	\$ 5,196.19
16	Permits	EA	0.5	0.5	\$ 31,500.00	\$ 15,750.00
17	Demolition	EA	1	1.0	\$ 16,807.95	\$ 16,807.95
19	Electrical for Equipment Relocation	EA	1	1.0	\$ 13,542.90	\$ 13,542.90
25	Plumbing Extension for New Filtration Equipment	EA	1	1.0	\$ 90,000.01	\$ 90,000.01
29	Portable Toilet	EA	0.5	0.5	\$ 1,800.00	\$ 900.00
30	Performance & Payment Bond	EA	0.5	0.5	\$ 11,068.03	\$ 5,534.02
21	Deck (Additional Area to CDD Engineer's Report 11-5-2019)	EA	1.0	1.0	\$ 162,266.72	\$ 162,266.72
TOTAL POOL					\$	467,275.50
DECK PROJECT (CDD FUNDS) (Per Original Engineer's Report of November 5, 2019)						
15	Light	EA	1	1.0	\$ 11,640.00	\$ 11,640.00
16	Permits	EA	0.5	0.5	\$ 31,500.00	\$ 15,750.00
17	Demolition	EA	1	1.0	\$ 5,692.05	\$ 5,692.05
18	Electrical Connections and More	EA	1	1.0	\$ 9,922.50	\$ 9,922.50
20	Pool Barrier	EA	1	1.0	\$ 63,665.70	\$ 63,665.70
21	Deck (Per original CDD Area Engineer's Report 11-5- 2019.	EA	1	1.0	\$ 54,952.03	\$ 54,952.03
22	Deco Drain/Drainage for Decks	EA	1	1.0	\$ 8,996.93	\$ 8,996.93
23	Concrete Work for New Pool Equipment Area	EA	1	1.0	\$ 13,419.00	\$ 13,419.00
24	Concrete Work for Retaining Wall	EA	1	1.0	\$ 77,080.50	\$ 77,080.50
26	Planter	EA	1	1.0	\$ 11,979.00	\$ 11,979.00
27	Deck Drainage System	EA	1	1.0	\$ 5,056.14	\$ 5,056.14
28	Pool Barrier: Construction Fencing	EA	1.0	1.0	\$ 4,940.03	\$ 4,940.03
29	Portable Toilet	EA	0.5	0.5	\$ 1,800.00	\$ 900.00
30	Performance & Payment Bond	EA	0.5	0.5	\$ 11,068.03	\$ 5,534.02
TOTAL DECK					\$	289,527.90
GRAND TOTAL					\$	756,803.40



CONSTRUCTION LETTER OF INTEREST

Date: 1/8/2023

Rockpower Paving , Corp.

13831 SW 59th Street, Ste 204 Miami FL 33183

Miami, FL, ZIP

CDDDBIDS@gmail.com

Project Location: 1020 Malibu Way , Homestead FL 33033

RE: MALIBU BAY CLUBHOUSE POOL DECK AND SWIMMING POOL EQUIPMENT IMPROVEMENTS.

This Letter of Intent (the “Letter”) sets forth the proposed terms and conditions of the Services described hereunder and shall govern the relationship between the Client and Contractor (the “Parties”) until replaced by a definitive, formal agreement addressing the same services and subject matter (the “Definitive Agreement”). The Services considered in this Letter and in the Definitive Agreement are subject in all respects to the following:

1. THE CONTRACTOR. Rockpower Paving Corp. (the “Contractor”) with a mailing address of 13831 SW 59th Street, Ste 204 Miami FL 33183
2. THE CLIENT. Stonegate Community Development District (the “Client”) with a mailing address of 1020 Malibu Bay, Homestead, FL 33033.
3. THE SERVICES. The Contractor agrees to provide the following services: Malibu Bay Clubhouse pool deck and swimming pool equipment improvements as described on the proposal. (the “Services”).



4. LOCATION. The Contractor shall perform services for the Client at the following primary location: 1020 Malibu Bay, Homestead FL 33033 (the "Location").
5. START AND END DATE. The Contractor shall start providing the Services on date of signed contract with deposit and the Services may be completed 7 months after construction begins.
6. INTENTION OF THE PARTIES. This Letter sets forth the intentions of the Parties to use reasonable efforts to negotiate, in good faith, a Definitive Agreement with respect to all matters herein. Any legal obligations with respect to all other matters shall only arise if and when the Parties execute and deliver a Definitive Agreement.
7. GOVERNING LAW. This Letter shall be governed by the laws of the State of Florida.
8. SIGNATURES.

Client Signature: _____ Date: _____

Print Name: _____

Contractor Signature:  _____ Date: 1/8/24

Print Name: Roberto Delgado



Rock Power Paving, Inc.
 13831 SW 59th Street, Suite 204
 Miami, FL 33183
 Ph: (305) 752-7742
 Fx: (305) 752-7728
estimating@rockpowerpaving.com

To:	Stonegate CDD District Engineer	Contact:	Victor
Address:	1020 NE 34 Avenue Homestead, FL 33033	Phone:	(239) 789-7263
Project Name:	Malibu Bay Clubhouse Pool Deck And Swimming Pool Equipment	Bid Number:	
Project Location:	1040 Malibu Way,, Homestead, FL	Bid Date:	1/8/2024

Item #	Item Description	Total Price
01	Diamond Brite Plaster For Pool <ul style="list-style-type: none"> • Remove Water With Submersible Pump. • Prep Pool By Removing Up To 30% Of Old Plaster. (If More Is Needed To Be Removed That Will Be At An Additional Cost) • Wash Pool With Chlorine And Seal All Light Niches Return Lines, Main Drain And Skimmer With Hydraulic Cement. • Bond Kote Pool And Plaster With Commercial Diamond Brite. 	\$82,500.00
02	Pool Cartridge Filter For Pool <ul style="list-style-type: none"> • Purchase, Deliver And Install (4) New Pentair CCP520 Cartridge fiLter 520 Sq Ft. • Remove Old fiLter And Install New Cartridge fiLter For Existing Pool. 	\$12,600.00
03	Pool Pump Equipment <ul style="list-style-type: none"> • Install New 15 Hp 3 - Phase Pump Pentair EQK1500 With 680 GPM Or Equivalent. • Install One New Pool Pump For Existing Pool. • PVC Piping Connections Plumbing Materials, Tax And Delivery Included. (Electrical Is Separate.) 	\$12,596.85
04	Collector Tank For Pool <ul style="list-style-type: none"> • Separation Tank Necessary For Commercial Pools To Eliminate Direct Suction. • 1100 Gallons Plumbing, Pvc And Other Materials Necessary For Installation Included. 	\$25,110.00
05	Chemical Feeder Pumps For Pool <ul style="list-style-type: none"> • Install One New Rolachem Model 555017 With Model RC305 38 GPD & RC307 77GPD For Pool Rolachem Pump For Chemical Injection Into The Pool . • Electrical And Plumbing Connecions Included. • For Chlorine And Acid Or Equivalent. 	\$4,200.00
06	Flowmeter For Pool <ul style="list-style-type: none"> • Plumbing Instrument Placed On Return Line To Measure Water fIOW Back To Pool. • Purchase, Deliver And Install. 	\$807.69
07	Diamond Brite Plaster For Wading Pool <ul style="list-style-type: none"> • Remove Water With Submersible Pump. • Prep Pool By Removing Up To 30% Of Old Plaster. (If More Is Needed To Be Removed That Will Be At An Additional Cost) • Wash Pool With Chlorine And Seal All Light Niches Return Lines, Main Drain And Skimmer With Hydraulic Cement. • Bond Kote Pool And Plaster With Commercial Diamond Brite. 	\$3,750.00
08	Collector Tank For Wading Pool <ul style="list-style-type: none"> • Separation Tank Necessary For Commercial Pools To Eliminate Direct Suction. • For Wading Pool. 125 Gallons 	\$5,370.00
09	Pool Cartridge filter For Wading Pool <ul style="list-style-type: none"> • Purchase, Deliver And Install (1) New Pentair CCP320 Cartridge fiLter 320 Sq Ft. • Remove Old Filter And Install New Cartridge Filter For Existing Wading Pool. 	\$2,625.00
10	Pump Equipment For Wading Pool <ul style="list-style-type: none"> • Install New Pentair WhisperfIOW Model Wf-23011771 Or Equivalent Install One New Pool Pump For Existing Wading Pool. 	\$2,055.00

Item #	Item Description	Total Price
	<ul style="list-style-type: none"> PVC Piping Connections Plumbing Materials, Tax And Delivery Included. (Electrical Is Separate.) 	
11	Flowmeter For Wading Pool <ul style="list-style-type: none"> Plumbing Instrument Placed On Return Line To Measure Water fLOW Back To Pool. Purchase, Deliver And Install For Wading Pool. Flowmeter And Installation Included. 	\$328.13
12	Vats For Chemicals <ul style="list-style-type: none"> Purchase Deliver And Install Chemical Vats For Pool And Spa. Chlorine And Acid 50 Gallons 	\$2,053.80
13	Chemical Feeder Pumps For Wading Pool <ul style="list-style-type: none"> One Rolachem Model 555017 With Model RC303 12 GPD & RC305 38 GPD For Wading Pool. Rolachem Pump For Chemical Injection Into The Pool . Electrical And Plumbing Connections Included. For Chlorine And Acid Or Equivalent 	\$3,281.25
14	Backflow Preventor <ul style="list-style-type: none"> Install 1 Freshwater Backflow Preventor For Water Fill Line City Of Homestead 	\$5,196.19
15	Light <ul style="list-style-type: none"> (8) Commercial White Lights 12V 150W To Include Installation And Connections 	\$11,640.00
16	Permits <ul style="list-style-type: none"> Permits And Processing Of Plans In The City Of Homestead For Pool, Wading Pool And Deck & Health Department Permits 	\$31,500.00
17	Demolition <ul style="list-style-type: none"> Remove Existing Pool Deck. Use Heavy Machinery To Pick Up Debris, Haul Away, And Dispose Of Properly. Remove Existing Equipment And Clear Area. Excavate Trench To New Location. Excavate Area Where New Concrete Pad Will Be Installed. Dumpster, Equipment And Labor Included. 	\$22,500.00
18	Electrical Connections And More <ul style="list-style-type: none"> Any And All Electrical Connections Needed To Be Able To Connect All New Equipment, Switches, Interruptors, Transformers, Contactors Etc. (From New Subpanels To New Pool Equipment.) 	\$9,922.50
19	Electrical For Equipment Relocation <ul style="list-style-type: none"> Commercial Pool Equipment Re-location, Electrical Materials And Labor To Connect New Sub-panels To Existing Electrical Service. (from Existing Service To The New Sub-panels.) 	\$13,542.90
20	Pool Barrier <ul style="list-style-type: none"> Fencing For Area Around Existing Pool Area, Pool Barrier Is Type Of Protection For The Pool That Does Not Allow Small Children And Animals Fall Into The Pool From Accidental Drowning And Such. Removing And Installation Of New Aluminum Fence, 4ft High With 4 Self Locking Gates (baby Fence) Linear Ft As Per Plans 	\$63,665.70
21	Deck <ul style="list-style-type: none"> Install Lime Rock Subgrade And Level. Purchase, Deliver And Install New Pavers For Around The Existing Pool Deck As Well As New Pool Deck Area. New Concrete Pavers From Tremron Or Gem Pavers. 15,100 Sq Ft 	\$217,218.75
22	Deco Drain/Drainage For Decks <ul style="list-style-type: none"> Pool Deck Deco Drains. Deco Drains Is A Drain Where The Water Will Roll Into And Be Carried Away To The Grass Area. Color Stainless Steel (The Existing One Cannot Be Kept During Demo It Will Get Damaged.) 	\$8,996.93
23	Concrete Work For New Pool Equipment Area <ul style="list-style-type: none"> Concrete fLOOR For Equipment Installation. As Per Plans 12ft X 32ft Area Freeform. Excavation Labor, Materials For Formation, Formation Labor, Concrete Pump And Concrete For New Equipment Area. 	\$13,419.00
24	Concrete Work For Retaining Wall <ul style="list-style-type: none"> Excavation And Proper Disposal Of Existing Retaining Wall. Permits, Processing, Inspections And Construction Of Pools New Retaining Wall 	\$77,080.50

****No Water Control Is Included****

Item #	Item Description	Total Price
25	Plumbing Extension For New Filtration Equipment Commercial Pool Equipment Re-location, Plumbing PVC Material And Connections Included As Well As Labor To Connect New Equipment In New Pool Equipment Location To Pool	\$90,000.01
26	Planter Construction Of New Concrete Planters For (As Per Plans) (2)6x6 And (9) 4x4	\$11,979.00
27	Deck Drainage System Installation, Material Equipment And Labor To Install 6 Drain Basins And Associated PCD Piping To Allow For Proper Deck Drainage.	\$5,056.14
28	Pool Barrier Furnish Labor, Material And Equipment To Install Temporary Chain-link Construction Fencing Around The Project, As Well As Orange Fencing On The Inside.	\$4,940.03
29	Portable Toilet Portable Toilet Rental For Construction Workers.	\$1,800.00
30	Performance & Payment Bond	\$11,068.03

Total Bid Price: \$756,803.40

Notes:

- **Proposal good for 60 days from : January 8, 2024**
- ROCK POWER PAVING shall guarantee all work and material. In accordance with the terms and conditions of this agreement and all work shall be completed in a workman-like manner and per standard practice of the prevailing county.
- ROCK POWER PAVING is only responsible for as-built on work performed by us. Legal Easements are not included in our scope and not the responsibility of ROCK POWER PAVING or our surveyor.
- ROCK POWER PAVING shall not be responsible for any loss, damage or injury to persons or property caused by acts of government civil or military authorities, theft, vandalism, labor disputes, explosion, power failure, water damage, storms, lightning, natural or public catastrophe, acts of God or by any other cause unavoidable or beyond our reasonable Control and, in any event, we shall not liable for incidental or consequential damages.
- ROCK POWER PAVING must be paid in full including retainage, to sign Final Release in Water Conveyance Package.
- The price is based on a continuous operation with no interruptions or delays. Any down time due to lack of access, interruption or delay not scheduled in advance caused by other activities will be an extra charges.
- Any change, alterations or deviation from the specifications as set forth in this agreement, which involves additional charge or cost, will be permitted only upon written change order and same will be an extra charge which shall be due and payable upon execution of the change order.
- In the event of your non-performance under the terms and conditions of this agreement or failure to pay the amount due within the time as set forth within the agreement, you agree that if an attorney is engaged to enforce the terms of this agreement, or to collect payment due hereunder either with or without suit, you shall pay all cost incurred by ROCK POWER PAVING, including reasonable attorney's fees in the trial court and the appellate level.
- It is agreed that you thereby waive trial by jury, and further agree and consent that venue shall for any proceeding under this agreement be in the County of Dade and State of Florida.
- The final payment shall be made within 30 days after the completion of the work covered by this contract and acceptance thereof by contractor, the architect and/or engineer.
- No agent or employee shall have the authority to waive or modify any of the terms and conditions of this agreement.
- If General Contractor/ Owner provides a separate contract this proposal must be signed as an attachment to contract.

<p>ACCEPTED: The above prices, specifications and conditions are satisfactory and are hereby accepted.</p> <p>Buyer: _____</p> <p>Signature: _____</p> <p>Date of Acceptance: _____</p>	<p>CONFIRMED: Rock Power Paving</p> <p>Authorized Signature:  _____</p> <p>Estimator: Roberto Delgado, President</p>
---	---



CERTIFICATE OF LIABILITY INSURANCE

DATE (MM/DD/YYYY)
06/30/2023

THIS CERTIFICATE IS ISSUED AS A MATTER OF INFORMATION ONLY AND CONFERS NO RIGHTS UPON THE CERTIFICATE HOLDER. THIS CERTIFICATE DOES NOT AFFIRMATIVELY OR NEGATIVELY AMEND, EXTEND OR ALTER THE COVERAGE AFFORDED BY THE POLICIES BELOW. THIS CERTIFICATE OF INSURANCE DOES NOT CONSTITUTE A CONTRACT BETWEEN THE ISSUING INSURER(S), AUTHORIZED REPRESENTATIVE OR PRODUCER, AND THE CERTIFICATE HOLDER.

IMPORTANT: If the certificate holder is an ADDITIONAL INSURED, the policy(ies) must have ADDITIONAL INSURED provisions or be endorsed. If SUBROGATION IS WAIVED, subject to the terms and conditions of the policy, certain policies may require an endorsement. A statement on this certificate does not confer rights to the certificate holder in lieu of such endorsement(s).

PRODUCER Brown & Brown of Florida, Inc. 8825 NW 21st Terrace Doral FL 33172		CONTACT NAME: Yamile Corral AAI, AAIM PHONE (A/C, No, Ext): (305) 714-4400 FAX (A/C, No): (305) 714-4401 E-MAIL ADDRESS: Yamile.Corral@bbrown.com	
		INSURER(S) AFFORDING COVERAGE	
		INSURER A: Everest Indemnity Insurance Company NAIC # 10851	
		INSURER B: Everest National Insurance Company 10120	
		INSURER C: The Burlington Insurance Company 23620	
		INSURER D: Bridgefield Casualty Insurance Company 10335	
		INSURER E: Federal Insurance Company 20281	
		INSURER F:	

COVERAGES **CERTIFICATE NUMBER:** 2023-2024 **REVISION NUMBER:**

THIS IS TO CERTIFY THAT THE POLICIES OF INSURANCE LISTED BELOW HAVE BEEN ISSUED TO THE INSURED NAMED ABOVE FOR THE POLICY PERIOD INDICATED. NOTWITHSTANDING ANY REQUIREMENT, TERM OR CONDITION OF ANY CONTRACT OR OTHER DOCUMENT WITH RESPECT TO WHICH THIS CERTIFICATE MAY BE ISSUED OR MAY PERTAIN, THE INSURANCE AFFORDED BY THE POLICIES DESCRIBED HEREIN IS SUBJECT TO ALL THE TERMS, EXCLUSIONS AND CONDITIONS OF SUCH POLICIES. LIMITS SHOWN MAY HAVE BEEN REDUCED BY PAID CLAIMS.

INSR LTR	TYPE OF INSURANCE	ADDL INSD	SUBR WVD	POLICY NUMBER	POLICY EFF (MM/DD/YYYY)	POLICY EXP (MM/DD/YYYY)	LIMITS	
A	<input checked="" type="checkbox"/> COMMERCIAL GENERAL LIABILITY <input type="checkbox"/> CLAIMS-MADE <input checked="" type="checkbox"/> OCCUR <input checked="" type="checkbox"/> Contractual Liability <input checked="" type="checkbox"/> XCU GEN'L AGGREGATE LIMIT APPLIES PER <input type="checkbox"/> POLICY <input checked="" type="checkbox"/> PROJECT <input type="checkbox"/> LOC <input type="checkbox"/> OTHER	Y	Y	CF3GL00397231	07/01/2023	07/01/2024	EACH OCCURRENCE \$ 2,000,000 DAMAGE TO RENTED PREMISES (Ea occurrence) \$ 100,000 MED EXP (Any one person) \$ 5,000 PERSONAL & ADV INJURY \$ 2,000,000 GENERAL AGGREGATE \$ 4,000,000 PRODUCTS - COMPI/OP AGG \$ 4,000,000 Employee Benefits \$ 1,000,000	
B	AUTOMOBILE LIABILITY <input checked="" type="checkbox"/> ANY AUTO <input type="checkbox"/> OWNED AUTOS ONLY <input type="checkbox"/> SCHEDULED AUTOS <input checked="" type="checkbox"/> HIRED AUTOS ONLY <input checked="" type="checkbox"/> NON-OWNED AUTOS ONLY			CF3CA00327231	07/01/2023	07/01/2024	COMBINED SINGLE LIMIT (Ea accident) \$ 1,000,000 BODILY INJURY (Per person) \$ BODILY INJURY (Per accident) \$ PROPERTY DAMAGE (Per accident) \$ \$	
C	<input type="checkbox"/> UMBRELLA LIAB <input checked="" type="checkbox"/> OCCUR <input checked="" type="checkbox"/> EXCESS LIAB <input type="checkbox"/> CLAIMS-MADE DED RETENTION \$			850BE08448	07/01/2023	07/01/2024	EACH OCCURRENCE \$ 3,000,000 AGGREGATE \$ 3,000,000 \$	
D	WORKERS COMPENSATION AND EMPLOYERS' LIABILITY ANY PROPRIETOR/PARTNER/EXECUTIVE OFFICER/MEMBER EXCLUDED? (Mandatory in NH) If yes, describe under DESCRIPTION OF OPERATIONS below	Y/N	N/A	Y	90199BIND	07/01/2023	07/01/2024	<input checked="" type="checkbox"/> PER STATUTE <input type="checkbox"/> OTH-ER E.L. EACH ACCIDENT \$ 1,000,000 E.L. DISEASE - EA EMPLOYEE \$ 1,000,000 E.L. DISEASE - POLICY LIMIT \$ 1,000,000
E	Inland Marine			45474608	07/01/2023	07/01/2024	Leased/Rented Equip. \$400,000	

DESCRIPTION OF OPERATIONS / LOCATIONS / VEHICLES (ACORD 101, Additional Remarks Schedule, may be attached if more space is required)

Primary & Non Contributory basis with respects to General Liability when required by written contract.
Waiver of subrogation applies to General Liability & Workers Compensation coverage when required by written contract.

CERTIFICATE HOLDER	CANCELLATION
	SHOULD ANY OF THE ABOVE DESCRIBED POLICIES BE CANCELLED BEFORE THE EXPIRATION DATE THEREOF, NOTICE WILL BE DELIVERED IN ACCORDANCE WITH THE POLICY PROVISIONS. AUTHORIZED REPRESENTATIVE 

© 1988-2015 ACORD CORPORATION. All rights reserved.



Professional References

Date: 01/08/2024

Rock Power Paving, Inc
13831 SW 59th Street, Ste 204
Miami Fl 33183

CDDBids@gmail.com

Project Location: 1020 Malibu Way, Homestead, FL. 33033

RE: MALIBU BAY CLUBHOUSE POOL DECK AND SWIMMING POOL EQUIPMENT IMPROVEMENTS.

- Lennar Homes : Pedro Portela, Lennar Homes, VP Land Development, pedro.portela@lennar.com, 786-367-2020
- Century Homes; Pedro Hernandez, Century Home Builders, VP , phernandez@chbsf.com
- Thomas Rasmussen, CEO CVO Lononno Concepts Development Group, 573-660-0935, thomasr@lononnoconcepts.com
- Lloyd Freeman: Parc Plaza Condominium, 1575 Washington Ave, Miami Beach, Fl Bldg. Manager, 305-385-4303



Similar Projects

Date: 01/08/2024

Rock Power Paving, Inc
13831 SW 59th Street, Ste 204
Miami FL 33183

CDDBids@gmail.com

Project Location: 1020 Malibu Way, Homestead, FL. 33033

RE: MALIBU BAY CLUBHOUSE POOL DECK AND SWIMMING POOL EQUIPMENT IMPROVEMENTS.

- Century Park South: New Commercial swimming pool and deck construction, Multi-home residential swimming pool projects
- Lononno Concepts Development Group ~ Commercial Construction : Cruz residence: 26700 SW 133 Ave, Miami, Fl
- Park Plaza: Lloyd Freeman 1775 Washington Ave, Miami Beach, Fl ~ Structural, plumbing, electrical and deck renovation of suspended 5th story commercial swimming pool.
- Old Cutler Cove: Christine Gieger 9010 SW 203 Terr, Miami, Fl 305-726-6581



Ron DeSantis, Governor

Melanie S. Griffin, Secretary



STATE OF FLORIDA
DEPARTMENT OF BUSINESS AND PROFESSIONAL REGULATION

CONSTRUCTION INDUSTRY LICENSING BOARD

THE GENERAL CONTRACTOR HEREIN IS CERTIFIED UNDER THE
PROVISIONS OF CHAPTER 489, FLORIDA STATUTES

GARCIA-MENOCAL, MARCO JACINTO

ROCK POWER PAVING, INC
13831 SW 59 STREET, SUITE 204
MIAMI FL 33183

LICENSE NUMBER: CGC060873

EXPIRATION DATE: AUGUST 31, 2024

Always verify licenses online at [MyFloridaLicense.com](https://www.MyFloridaLicense.com)

ISSUED: 01/08/2024

Do not alter this document in any form.

This is your license. It is unlawful for anyone other than the licensee to use this document.





**STATE OF FLORIDA
DEPARTMENT OF BUSINESS AND PROFESSIONAL REGULATION**

2601 BLAIR STONE ROAD
TALLAHASSEE FL 32399-0783

Congratulations! With this license you become one of the nearly one million Floridians licensed by the Department of Business and Professional Regulation. Our professionals and businesses range from architects to yacht brokers, from boxers to barbeque restaurants, and they keep Florida's economy strong.

Every day we work to improve the way we do business in order to serve you better. For information about our services, please log onto www.myfloridalicense.com. There you can find more information about our divisions and the regulations that impact you, subscribe to department newsletters and learn more about the Department's initiatives.

Our mission at the Department is: License Efficiently, Regulate Fairly. We constantly strive to serve you better so that you can serve your customers. Thank you for doing business in Florida, and congratulations on your new license!

Florida dbpr STATE OF FLORIDA DEPARTMENT OF BUSINESS AND PROFESSIONAL REGULATION

CPC057101 ISSUED: 07/29/2022
 CERT COMMERCIAL POOL/SPA CONTR
 VIGIL, PEDRO
 TRUE BLUE POOLS CONTRACTING, INC.

 Signature
 LICENSED UNDER CHAPTER 489, FLORIDA STATUTES
 EXPIRATION DATE: AUGUST 31, 2024

Ron DeSantis, Governor

Melanie S. Griffin, Secretary

**STATE OF FLORIDA
DEPARTMENT OF BUSINESS AND PROFESSIONAL REGULATION
CONSTRUCTION INDUSTRY LICENSING BOARD**

LICENSE NUMBER: CPC057101

EXPIRATION DATE: AUGUST 31, 2024

THE COMMERCIAL POOL/SPA CONTRACTOR HEREIN IS CERTIFIED UNDER THE PROVISIONS OF CHAPTER 489, FLORIDA STATUTES

VIGIL, PEDRO
TRUE BLUE POOLS CONTRACTING, INC.
18495 S DIXIE HWY 378
MIAMI FL 33157



ISSUED: 07/29/2022

Always verify licenses online at MyFloridaLicense.com
Do not alter this document in any form.

This is your license. It is unlawful for anyone other than the licensee to use this document.

006509

Municipal Contractor's Receipt

Miami-Dade County, State of Florida
-THIS IS NOT A BILL - DO NOT PAY



5640264

BUSINESS NAME/LOCATION
ROCK POWER PAVING INC
13831 SW 59TH ST STE 204
MIAMI FL 33183-1150

RECEIPT NO.
NEW
7665932

EXPIRES
SEPTEMBER 30, 2024

Must be displayed at place of business
Pursuant to County Code
Chapter 8A - Art. 9 & 10

OWNER
ROCK POWER PAVING INC
C/O ROBERTO DELGADO, PRES

SEC. TYPE OF BUSINESS
MMC SPECIALTY ENGINEERING CONTRACTOR
E251800

PAYMENT RECEIVED
BY TAX COLLECTOR
\$225.00 09/11/2023
INT-23-452290

Category(s) 3

This Local Business Tax Receipt only confirms payment of the Local Business Tax. The Receipt is not a license, permit, or a certification of the holder's qualifications, to do business. Holder must comply with any governmental or nongovernmental regulatory laws and requirements which apply to the business.

The RECEIPT NO. above must be displayed on all commercial vehicles - Miami-Dade Code Sec 8a-276.

For more information, visit www.miamidade.gov/taxcollector

006349

Local Business Tax Receipt

Miami-Dade County, State of Florida
-THIS IS NOT A BILL - DO NOT PAY



7361244

BUSINESS NAME/LOCATION
ROCK POWER PAVING INC
13831 SW 59TH ST STE 204
MIAMI FL 33183-1150

RECEIPT NO.
RENEWAL
7655422

EXPIRES
SEPTEMBER 30, 2024

Must be displayed at place of business
Pursuant to County Code
Chapter 8A - Art. 9 & 10

OWNER
ROCK POWER PAVING INC
HECTOR PAREDES, QUALIFIER

SEC. TYPE OF BUSINESS
196 SPECIALTY ENGINEERING CONTRACTOR
CUC1224270

PAYMENT RECEIVED
BY TAX COLLECTOR
\$75.00 09/11/2023
INT-23-452216

Worker(s) 1

This Local Business Tax Receipt only confirms payment of the Local Business Tax. The Receipt is not a license, permit, or a certification of the holder's qualifications, to do business. Holder must comply with any governmental or nongovernmental regulatory laws and requirements which apply to the business.

The RECEIPT NO. above must be displayed on all commercial vehicles - Miami-Dade Code Sec 8a-276.

For more information, visit www.miamidade.gov/taxcollector

MARCO GARCIA-MENOCAL

(786)344-4896

marcojgm@aol.com

EDUCATION

1992-1996 Florida International University. Miami, Fl.
Bachelor of Science in Construction Management

EXPERIENCE & BACKGROUND

03-2021 to Present ROCK POWER PAVING, Miami, Fl.
SENIOR ESTIMATOR

05-2015 to 02-2021 THE REDLAND COMPANY Homestead, Fl.
SENIOR ESTIMATOR

08-2010 to 05-2015 WESTWIND CONTRACTING, INC. Pembroke Park, Fl.
AREA MANAGER, CHIEF ESTIMATOR, SENIOR PROJECT MANAGER

06-2005 to 07-2010 MASTER EXCAVATORS, INC. Miami, Fl.
SENIOR ESTIMATOR, PROJECT MANAGER

05-2001 to 06-2005 WESTWIND CONTRACTING, INC. Pembroke Park, Fl.
CHIEF ESTIMATOR, PROJECT MANAGER

07-2000 to 05-2001 RYAN INCORPORATED EASTERN. Deerfield Beach, Fl.
SENIOR ESTIMATOR, CHIEF SCHEDULER

06-1995 to 07-2000 SMITH & COMPANY, Inc. Weston, Fl.
ESTIMATOR / SCHEDULER/ASSISTANT PROJECT MANAGER

CERTIFICATIONS

- State of Florida License No. CG C060873 Certified General Contractor
- State of Florida License No. CUC1224724 Certified Underground Utility Excavation
- Certified NPDES Inspector, Florida Department of Environmental Protection
- ATSSA Advanced Certification in Traffic Control Design and Maintenance
- OSHA (Occupational Safety & Health Administration) 30 Hour Certification
- PADI Open Water Diving

COMPUTER SKILLS

- Suretrac Project Scheduler
- HCSS Estimating Software
- Bid2Win Estimating Software
- AGTEK

MARCO GARCIA-MENOCAL

(786)344-4896

marcojgm@aol.com

LANGUAGES

English
Spanish

REFERENCES

Available upon request

INDEX OF SHEETS
SHEET NO. SHEET DESCRIPTION

1	KEY SHEET
2	GENERAL NOTES
3	PAVING, GRADING AND DRAINAGE PLAN
4	DETAILS
1	TOPOGRAPHIC SURVEY

**PROPOSED
IMPROVEMENTS TO**

**POOL DECK AT
STONEGATE COMMUNITY DEVELOPMENT DISTRICT
MALIBU BAY CLUBHOUSE
1020 NE 34 AVENUE
HOMESTEAD, FL. 33033
MIAMI-DADE COUNTY
FOLIO NO. 10-7910-009-0030**

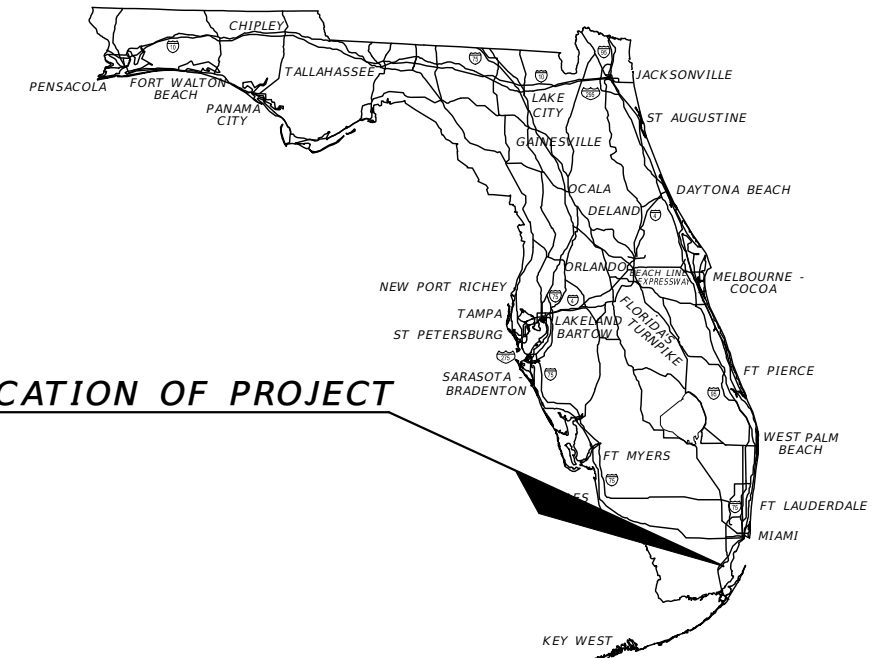

LOCATION OF PROJECT

SHOP DRAWINGS
TO BE SUBMITTED TO:

REYNALDO R. CHINEA
FL PE LIC. NO. 58579
ALVAREZ ENGINEERS, INC.
8935 NW 35 LANE, SUITE 101
MIAMI, FL 33172

PREPARED BY:

Alvarez Engineers, Inc.

FLORIDA CERTIFICATE OF AUTHORIZATION No. 7538
8935 N.W. 35 LANE, Suite 101
Doral, Florida 33172
Tel. (305) 640-1345 Fax (305) 640-1346

PREPARED FOR:
STONEGATE CDD

**POOL DECK PLANS
ENGINEER OF RECORD:**

REYNALDO R. CHINEA
FL PE LIC. NO. 58579
ALVAREZ ENGINEERS, INC.
8935 NW 35 LANE, SUITE 101
MIAMI, FL 33172
CERTIFICATE OF AUTHORIZATION 7538

GOVERNING DESIGN STANDARDS:

Florida Department of Transportation, FY2021-22 Standards Plans eBook (SPeB) and applicable Standard Plans Revisions (SPRs) at the following website:
<https://www.fdot.gov/design/standardplans>

GOVERNING STANDARD SPECIFICATIONS:

Florida Department of Transportation, JULY-2022 Standard Specifications for Road and Bridge Construction at the following website:
<http://www.fdot.gov/programmanagement/Implemented/SpecBooks>

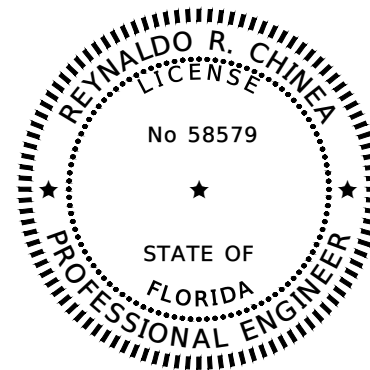

THIS ITEM HAS BEEN DIGITALLY
SIGNED AND SEALED BY REYNALDO R. CHINEA,
ON 01/11/2023.

PRINTED COPIES OF THIS DOCUMENT ARE
NOT CONSIDERED SIGNED AND SEALED
AND THE SIGNATURE MUST BE VERIFIED
ON ANY ELECTRONIC COPIES.

SHEET
NO.

1

KEY SHEET

NOT FOR CONSTRUCTION
PRELIMINARY AND SUBJECT TO CHANGE

GENERAL:

1. BENCHMARK ELEVATIONS SHOWN ON THE PLANS ARE NATIONAL GEODETIC VERTICAL DATUM OF 1929 (NGVD 29).
2. THE CONTRACTOR SHALL BE RESPONSIBLE FOR ENSURING THAT ALL CONSTRUCTION SHALL BE DONE IN A SAFE MANNER AND IN STRICT COMPLIANCE WITH ALL THE REQUIREMENTS OF THE FEDERAL OCCUPATIONAL SAFETY AND HEALTH ACT LATEST EDITION, AND ALL STATE AND LOCAL SAFETY AND HEALTH REGULATIONS.

UTILITIES

1. THE LOCATION OF THE UTILITIES SHOWN IN THE PLANS ARE BASED ON LIMITED INVESTIGATION TECHNIQUES AND SHOULD BE CONSIDERED APPROXIMATE ONLY. THE VERIFIED LOCATIONS/ELEVATIONS APPLY ONLY AT THE POINTS SHOWN. ADDITIONAL UTILITIES MAY EXIST WHICH ARE NOT SHOWN ON THESE DRAWINGS. THE CONTRACTOR SHALL VERIFY ALL UTILITIES BY ELECTRONIC METHODS AND BY PRE-TRENCHING IN COORDINATION WITH ALL UTILITY COMPANIES, PRIOR TO BEGINNING ANY CONSTRUCTION OPERATION. ANY AND ALL CONFLICTS OF EXISTING UTILITIES WITH PROPOSED IMPROVEMENTS MUST BE RESOLVED BY THE ENGINEER AND THE OWNER. THIS WORK BY THE CONTRACTOR SHALL BE CONSIDERED INCIDENTAL TO THE CONTRACT AND NO ADDITIONAL COMPENSATION SHALL BE ALLOWED.

PRE-CONSTRUCTION RESPONSIBILITIES

1. THE INFORMATION PROVIDED IN THESE PLANS IS TO ASSIST THE CONTRACTOR IN ASSESSING THE NATURE AND EXTENT OF THE CONDITIONS WHICH MAY BE ENCOUNTERED DURING THE COURSE OF THE WORK. ALL CONTRACTORS ARE DIRECTED, PRIOR TO BIDDING, TO CONDUCT ANY INVESTIGATIONS THEY DEEM NECESSARY TO ARRIVE AT THEIR OWN CONCLUSIONS REGARDING THE ACTUAL CONDITIONS THAT WILL BE ENCOUNTERED AND UPON WHICH THEIR BIDS WILL BE BASED.
2. UPON THE RECEIPT OF THE "NOTICE TO PROCEED", THE CONTRACTOR SHALL CONTACT THE ENGINEER OF RECORD AND ARRANGE A PRE-CONSTRUCTION CONFERENCE TO INCLUDE ALL INVOLVED GOVERNMENTAL AGENCIES, UTILITY OWNERS, THE OWNER AND, THE ENGINEER OF RECORD.
3. THE CONTRACTOR SHALL CONTACT "SUNSHINE ONE-CALL OF FLORIDA" BY CALLING 811 AT LEAST 48 HOURS PRIOR TO COMMENCING ANY EXCAVATION OR CONSTRUCTION IN ORDER TO PROVIDE FOR THE LOCATION OF EXISTING UNDERGROUND UTILITIES.
4. THE CONTRACTOR SHALL COORDINATE WITH UTILITIES OWNERS TO ARRANGE FOR RELOCATION AND TEMPORARY SUPPORT OF UTILITY FEATURES, ETC. AS NECESSARY TO COMPLETE THE WORK, IF APPLICABLE.
5. IT SHALL BE THE CONTRACTOR'S RESPONSIBILITY TO LOCATE AND PROTECT ANY AND ALL EXISTING UTILITIES ON THIS PROJECT.
6. THE CONTRACTOR SHALL SECURE ALL UTILITY EASEMENTS (IF REQUIRED) TO BE SECURED PRIOR TO CONSTRUCTION.
7. LOCATIONS, ELEVATIONS, AND DIMENSIONS OF EXISTING UTILITIES, STRUCTURES, AND OTHER FEATURES AS SHOWN ON THE DRAWINGS WERE OBTAINED FROM A SURVEY PREPARED BY LONGITUDE SURVEYORS LLC DATED NOV. 24, 2015 AND THE BEST INFORMATION AVAILABLE AT THE TIME PLANS WERE PREPARED BUT DO NOT PURPORT TO BE ABSOLUTELY CORRECT. THERE MAY BE OTHER IMPROVEMENTS, UTILITIES, ETC., WITHIN THE PROJECT AREA WHICH WERE INSTALLED AND CONSTRUCTED AFTER THE PREPARATION OF THESE PLANS. THE ENGINEER ASSUMES NO RESPONSIBILITY FOR THE FACILITIES SHOWN OR FOR ANY FACILITIES NOT SHOWN. THE CONTRACTOR SHALL VERIFY, PRIOR TO CONSTRUCTION, THE LOCATIONS, ELEVATIONS AND DIMENSIONS OF ALL EXISTING FACILITIES, STRUCTURES AND OTHER FEATURES (WHETHER SHOWN ON THE PLANS OR NOT) AFFECTING THE WORK.
8. IF, UPON EXCAVATION, EXISTING CONDITIONS ARE FOUND TO BE IN CONFLICT WITH THE PROPOSED CONSTRUCTION, THE CONTRACTOR SHALL IMMEDIATELY NOTIFY THE ENGINEER OF RECORD SO THAT APPROPRIATE MEASURES CAN BE TAKEN TO RESOLVE THE PROBLEM.
9. CONTRACTOR SHALL SHOW HARD COPIES OF ALL PROPOSED STANDARD DETAILS AND SPECIFICATIONS AT THE PRE-CONSTRUCTION MEETING TO BE SIGNED BY THE ENGINEER & KEEP THEM IN THE PROJECT LOCATION.

INSPECTION AND TESTING:

1. THE CONTRACTOR SHALL NOTIFY THE ENGINEER OF RECORD, CITY OF HOMESTEAD BUILDING DEPARTMENT 48 HOURS PRIOR TO COMMENCING CONSTRUCTION.
2. THE CONTRACTOR SHALL GIVE THE ENGINEER OF RECORD AT LEAST 48 HOURS ADVANCE NOTICE, AND THE ENGINEER OF RECORD MUST BE PRESENT TO WITNESS FINAL INSPECTION OF PAVING, GRADING AND DRAINAGE.
3. IT IS THE RESPONSIBILITY OF THE CONTRACTOR TO CONTACT ALL APPLICABLE REGULATORY AGENCIES FOR INSPECTION REQUIREMENTS. THE ENGINEER OF RECORDS INSPECTION SHALL NOT REPLACE THE INSPECTIONS OF THOSE REGULATORY AGENCIES TO CERTIFY THE JOB OR PORTION OF THE JOB
4. CONTRACTOR TO RELOCATE, ADJUST ALL WATER AND SEWER, ELECTRIC AND CABLE UTILITIES AND DEVICES LOCATED WITHIN THE WORK ZONE. ALSO, ALL THE LANDSCAPE IMPACTED WITHIN THE WORK ZONE.

SHOP DRAWINGS:

PRIOR TO THEIR CONSTRUCTION OR INSTALLATION, SHOP DRAWINGS IF APPLICABLE SHALL BE SUBMITTED TO AND APPROVED BY THE ENGINEER OF RECORD FOR, BUT NOT LIMITED TO, THE FOLLOWING ITEMS: GRAVITY WALL, FENCES & DRAINAGE SYSTEM COMPONENTS. SOME CITY, COUNTY, STATE AND/OR NATIONAL REGULATORY AGENCIES REQUIRE THEIR OWN INDIVIDUAL REVIEW AND APPROVAL IT IS THE RESPONSIBILITY OF THE CONTRACTOR TO OBTAIN ALL OTHER AGENCY SHOP DRAWING APPROVALS IF REQUIRED.

TEMPORARY FACILITIES:

1. TEMPORARY FACILITIES:
 - A. IT SHALL BE THE CONTRACTOR'S RESPONSIBILITY TO ARRANGE FOR OR SUPPLY TEMPORARY WATER SERVICE, SANITARY FACILITIES, AND ELECTRICITY, DURING CONSTRUCTION.
 - B. THE CONTRACTOR SHALL MAINTAIN AT LEAST ONE ACCESS ENTRANCE TO COMMERCIAL PROPERTIES AT ALL TIMES, IF APPLICABLE.
 - C. THE CONTRACTOR SHALL MAINTAIN A CLEAR PATH FOR ALL SURFACE WATER DRAINAGE STRUCTURES AND DITCHES DURING ALL PHASES OF CONSTRUCTION, IF APPLICABLE.
2. TRAFFIC REGULATION:
 - A. THE CONTRACTOR SHALL PROVIDE ALL WARNING SIGNALS, SIGNS, LIGHTS AND FLAG PERSONS AS NECESSARY FOR THE MAINTENANCE OF TRAFFIC IN ACCORDANCE WITH THE MUTCD 2009, AND MIAMI-DADE COUNTY PUBLIC WORKS.
 - B. ALL OPEN TRENCHES AND HOLES ADJACENT TO ROADWAYS OR WALKWAYS SHALL BE PROPERLY MARKED AND BARRICADED TO ASSURE THE SAFETY OF BOTH VEHICULAR AND PEDESTRIAN TRAFFIC.
 - C. NO TRENCHES OR HOLES NEAR WALKWAYS, IN ROADWAYS OR THEIR SHOULDERS ARE TO BE LEFT OPEN DURING NIGHTTIME HOURS WITHOUT EXPRESS PERMISSION OF THE MIAMI-DADE COUNTY PUBLIC WORKS DEPARTMENT.

NOT FOR CONSTRUCTION
PRELIMINARY AND SUBJECT TO CHANGE

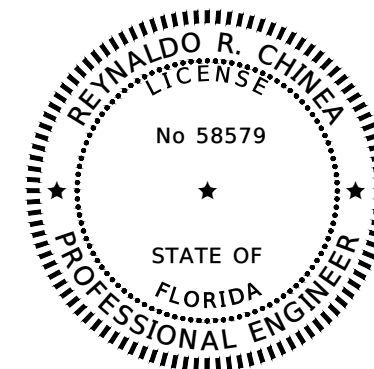

THIS ITEM HAS BEEN DIGITALLY SIGNED AND SEALED BY REYNALDO R. CHINEA, ON 01/11/2023.

PRINTED COPIES OF THIS DOCUMENT ARE NOT CONSIDERED SIGNED AND SEALED AND THE SIGNATURE MUST BE VERIFIED ON ANY ELECTRONIC COPIES.

REVISIONS				Alvarez Engineers, Inc. FLORIDA CERTIFICATE OF AUTHORIZATION No. 7538 8935 N.W. 35 Lane, Suite 101 Doral, Florida 33172 Tel. (305) 640-1345 Fax (305) 640-1346	STONEGATE CDD		GENERAL NOTES	SHEET NO. 2
DATE	DESCRIPTION	DATE	DESCRIPTION		LOCATION	COUNTY		
					POOL DECK	MIAMI-DADE		

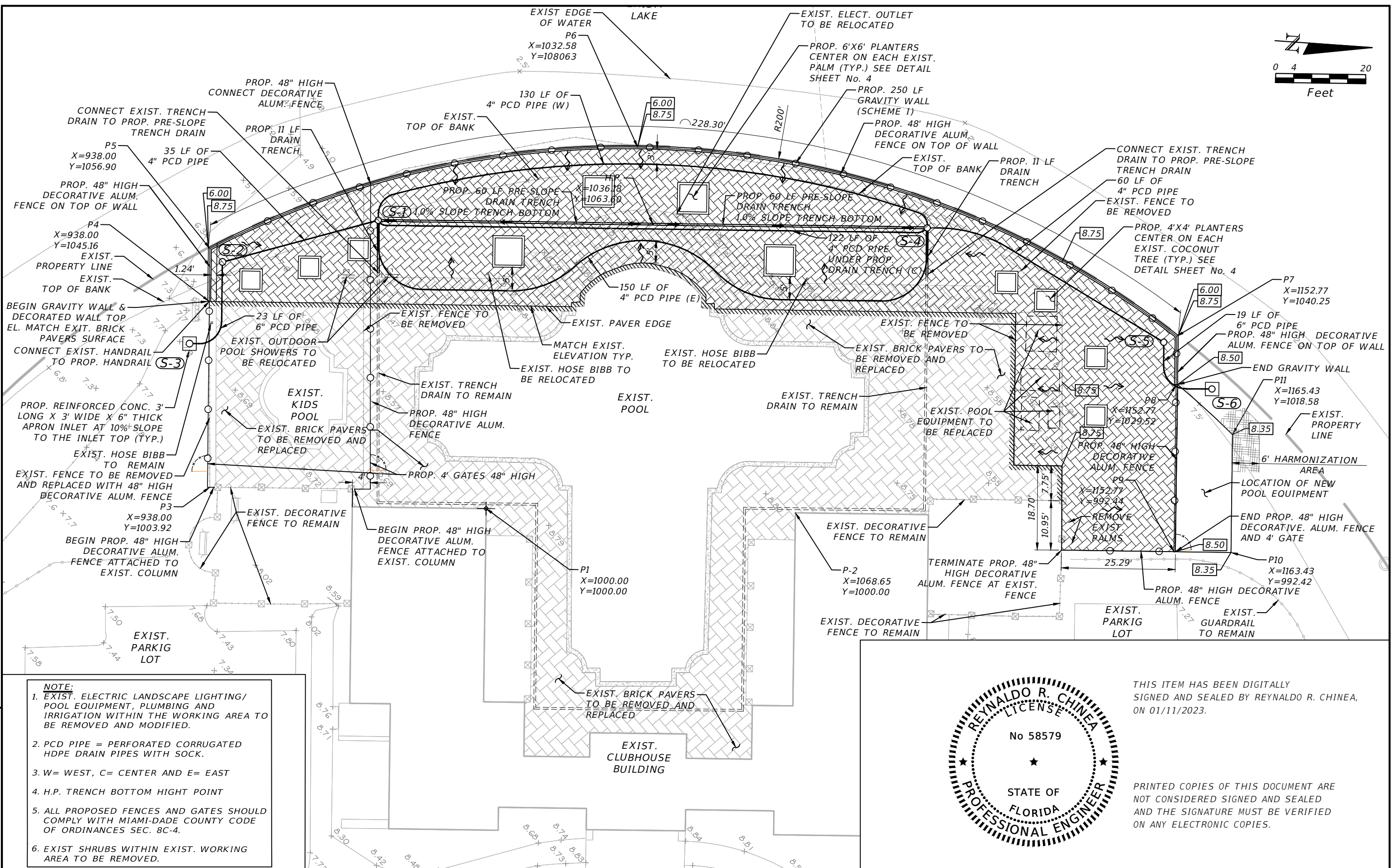
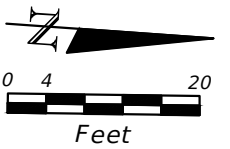

- NOTE:**
- EXIST. ELECTRIC LANDSCAPE LIGHTING/ POOL EQUIPMENT, PLUMBING AND IRRIGATION WITHIN THE WORKING AREA TO BE REMOVED AND MODIFIED.
 - PCD PIPE = PERFORATED CORRUGATED HDPE DRAIN PIPES WITH SOCK.
 - W= WEST, C= CENTER AND E= EAST
 - H.P. TRENCH BOTTOM HIGHT POINT
 - ALL PROPOSED FENCES AND GATES SHOULD COMPLY WITH MIAMI-DADE COUNTY CODE OF ORDINANCES SEC. 8C-4.
 - EXIST SHRUBS WITHIN EXIST. WORKING AREA TO BE REMOVED.

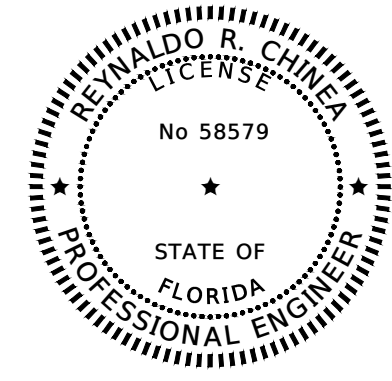

THIS ITEM HAS BEEN DIGITALLY SIGNED AND SEALED BY REYNALDO R. CHINEA, ON 01/11/2023.

PRINTED COPIES OF THIS DOCUMENT ARE NOT CONSIDERED SIGNED AND SEALED AND THE SIGNATURE MUST BE VERIFIED ON ANY ELECTRONIC COPIES.

NOT FOR CONSTRUCTION
PRELIMINARY AND SUBJECT TO CHANGE

REVISIONS	
DATE	DESCRIPTION

Alvarez Engineers, Inc.
 FLORIDA CERTIFICATE OF AUTHORIZATION No. 7538
 8935 N.W. 35 Lane, Suite 101
 Doral, Florida 33172
 Tel. (305) 640-1345 Fax (305) 640-1346

STONEGATE CDD

LOCATION	COUNTY
POOL DECK	MIAMI-DADE

PAVING, GRADING AND DRAINAGE PLAN

SHEET NO.
3

TABULATION OF DRAINAGE STRUCTURES																	
NO.	STRUCTURES								PIPES								
	ADS-NYOPLAT STRUCTURES			SIZE (IN)		LOCATION (FT)		ELEVATION (FT)		STRUCTURE		PIPE TYPE	SIZE (IN)	LENGTH (FT)	INVERT (FT)		REMARKS
	TYPE	CODE	GRATE CODE	BODY	TOP	X	Y	TOP	BOTTOM	I	TO				FROM	TO	
S-1	DRAIN BASIN	2808AG	0899CGS	12	12	937.55	1032.58	8.50	3.50	HP1	S-1	TD	4	60	8.17	6.57	
S-2	DRAIN BASIN	2808AG	0899CGS	8	8	940.80	1053.96	8.75	3.50	S-1	S-2	PP	4	35	5.50	5.50	
S-3	DRAIN BASIN	2812AG	1299CGC	8	8	933.73	1035.74	7.75	3.25	S-2	S-3	PP	6	23	5.50	5.25	APRON
S-4	DRAIN BASIN	2808AG	0899CGS	8	8	1097.11	1063.55	8.50	3.50	HP1	S-4	TD	4	60	8.17	6.57	
S-5	DRAIN BASIN	2808AG	0899CGS	8	8	1149.93	1038.84	8.75	3.50	S-4	S-05	PP	4	60	5.50	5.50	
S-6	DRAIN BASIN	2812AG	1299CGC	12	12	1160.77	1028.62	7.75	3.25	S-05	S-6	PP	6	19	5.50	5.25	APRON
HIGH POINT								1036.18	1063.60	S-1	S-4	PP	4	130	5.50	5.50	W
P1								1000.00	1000.00	S-1	S-4	PP	4	122	5.50	5.50	C
P2								1068.65	1000.00	S-1	S-4	PP	4	150	5.50	5.50	E

ITEM	DESCRIPTION	UNIT	QUANTITY
1	8" DRAIN BASIN WITH SOLID GRATE	EA	4
2	12" DRAIN BASIN WITH SOLID H-20 GRATE	EA	2
3	PRE-SLOPE TRENCH DRAIN	LF	142
4	4" PERFORATED CORRUGATED HDPE DRAIN PIPE WITH SOCK	LF	497
5	6" PERFORATED CORRUGATED HDPE DRAIN PIPE WITH SOCK	LF	42
6	2.75' HEIGHT CONCRETE GRAVITY WALL	LF	250
7	48" HEIGHT ALUMINUM DECORATIVE FENCE	LF	427
8	4'X4'X6"X9" CONCRETE PLANTERS	EA	7
9	6'X6'X6"X9" CONCRETE PLANTERS	EA	4
10	3'X3'X6" REINFORCED (4'X4" WIRE MESH) CONCRETE APRON	EA	2
11	PAVER AREA FOR DECK	SF	6,390

TECHNICAL DATA FOR SELECTION OF DRAIN BASINS AND GRATES AT THE LINKS BELOW:
<https://assets.ads-pipe.com/web/9b6371e24b98f688/website-documentation/?mediald=A1C9968A-EF16-477F-9EC2C85A54DB0099>

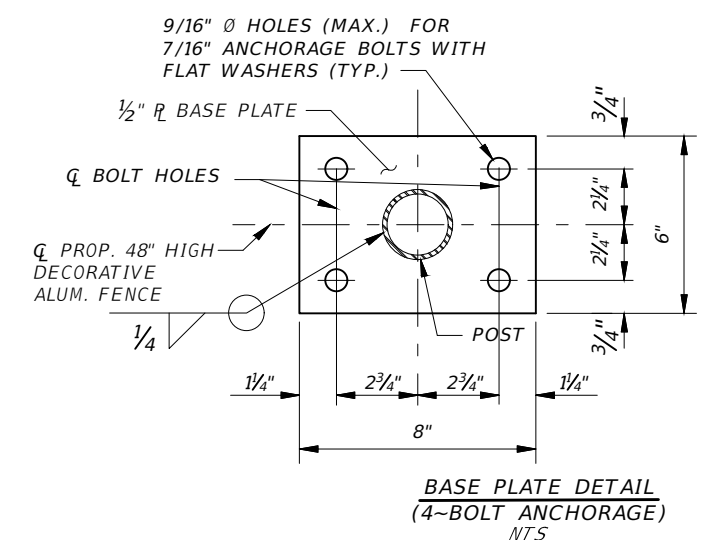
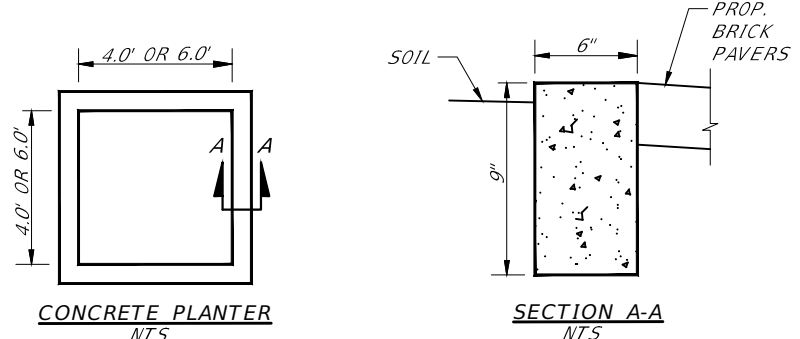
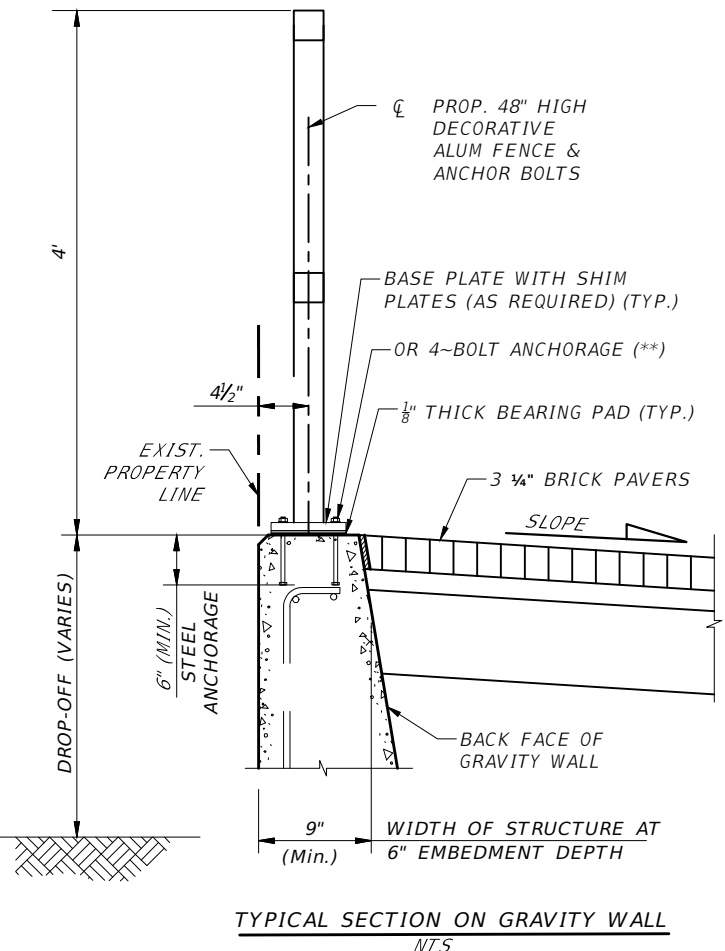
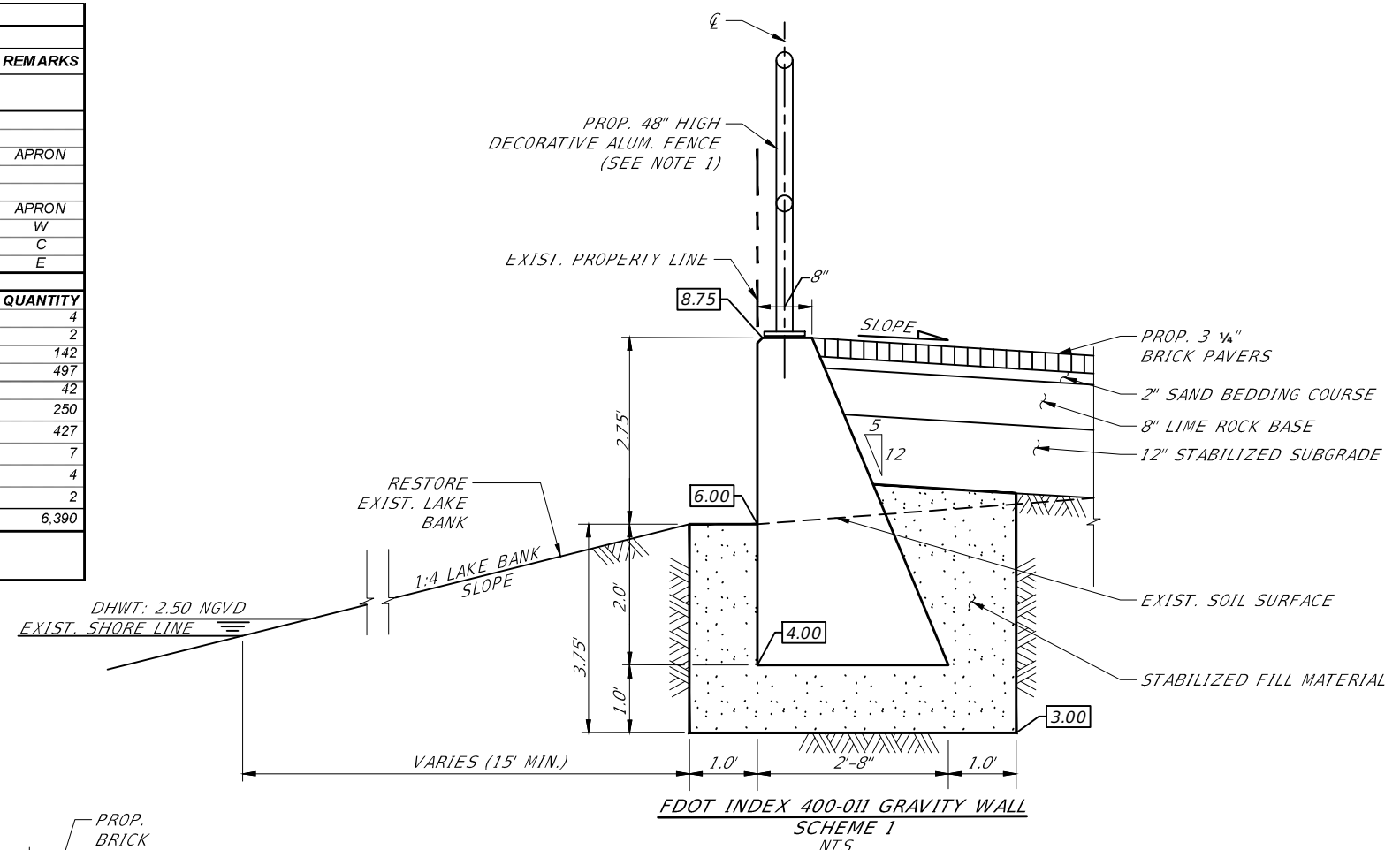

- NOTES:
1. WHEN REQUIRED, FOR ADJUNCT GUIDERAIL, SEE INDEX 215-070 OR 515-080 AS APPROPRIATE. FOR ADJUNCT TYPE B FENCE SEE INDEX 550-002.
 2. 12" SUBGRADE & FILL MATERIAL SHALL BE COMPACTED TO A MINIMUM OF 95% OF THE MAXIMUM DENSITY (AASHTO T-180), LBR 40.
 3. BASE ROCK MATERIAL FOR BRICK PAVER AREAS SHALL BE OF 8 INCHES PLACED ON A SINGLE LAYER. BASE SHALL BE COMPACTED TO 98% OF THE MAXIMUM DENSITY AS PER AASHTO T-180, LBR 100.
 4. BRICK PAVERS TO BE 3 1/4" THICK.
 5. ** 4 ~ 7/16" Ø X 6" STEEL ANCHORS: PERMITTED (C-I-P); GALVANIZED ADHESIVE ANCHORS PERMITTED.
 6. GRAVITY WALL DESIGN TO BE ACCORDING TO FDOT STANDARD PLAN 400-011 AND STANDARD SPECIFICATION SECTION 548.

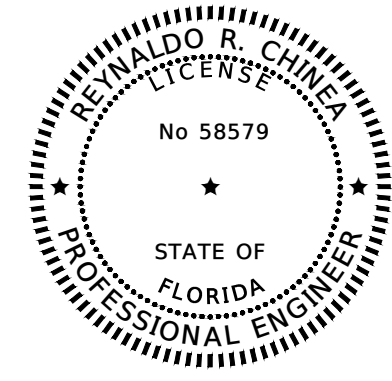

THIS ITEM HAS BEEN DIGITALLY SIGNED AND SEALED BY REYNALDO R. CHINEA, ON 01/11/2023.

PRINTED COPIES OF THIS DOCUMENT ARE NOT CONSIDERED SIGNED AND SEALED AND THE SIGNATURE MUST BE VERIFIED ON ANY ELECTRONIC COPIES.

NOT FOR CONSTRUCTION PRELIMINARY AND SUBJECT TO CHANGE

REVISIONS			
DATE	DESCRIPTION	DATE	DESCRIPTION

Alvarez Engineers, Inc.
 FLORIDA CERTIFICATE OF AUTHORIZATION No. 7538
 8935 N.W. 35 Lane, Suite 101
 Dorland, Florida 33172
 Tel. (305) 640-1345 Fax (305) 640-1346

STONEGATE CDD	
LOCATION	COUNTY
POOL DECK	MIAMI-DADE

DETAILS	
SHEET NO. 4	

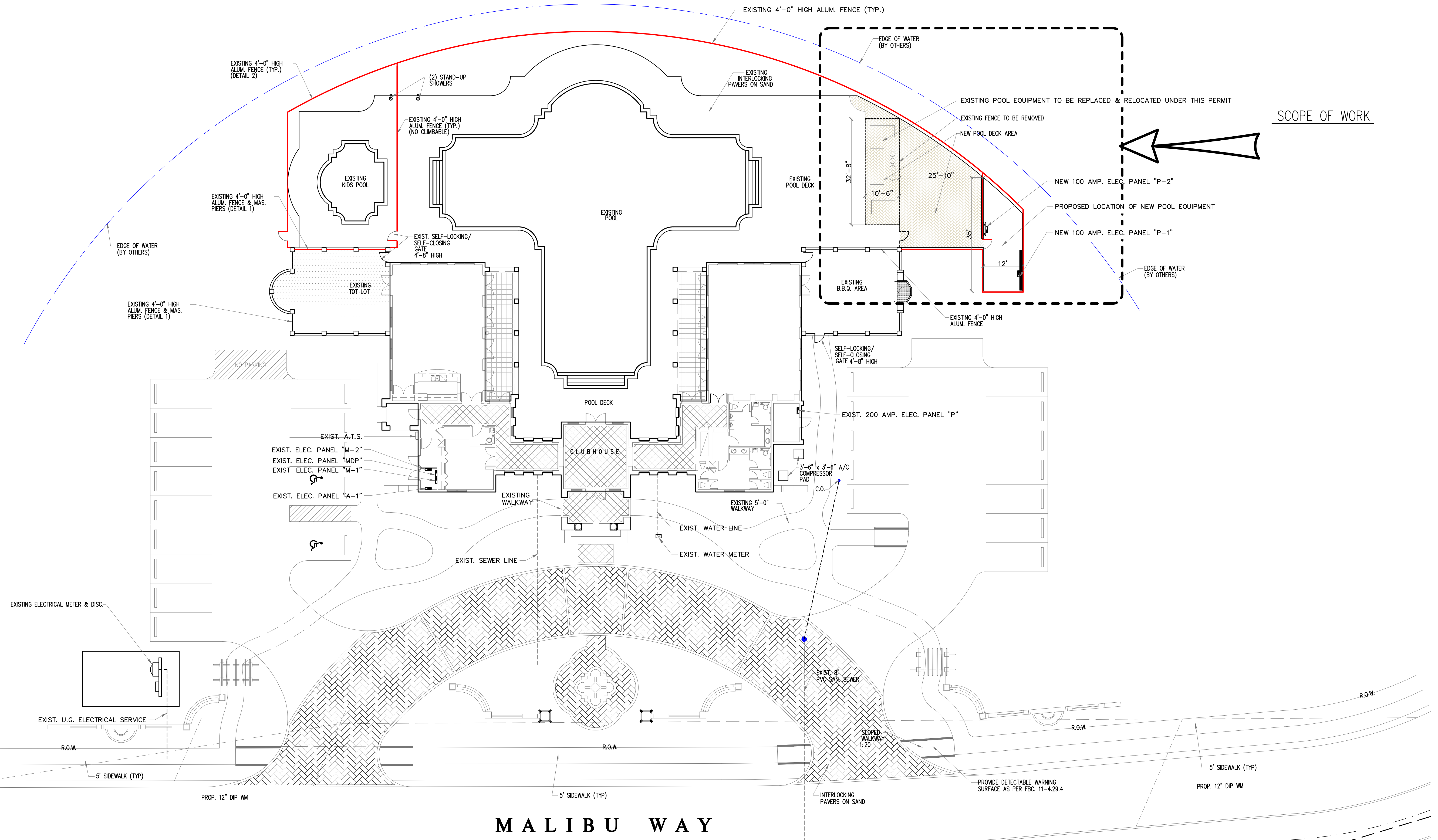

SCOPE OF WORK

MALIBU WAY

SITE PLAN
SCALE: 1/16"=1'-0"

THIS ITEM HAS BEEN ELECTRONICALLY SIGNED AND SEALED BY VICENTE FRANCO ON THE DATE ADJACENT TO THE SEAL USING A AUTHENTICATION CODE.
PRINTED COPIES OF THIS DOCUMENT ARE NOT CONSIDERED SIGNED AND SEALED AND THE AUTHENTICATION CODE MUST BE VERIFIED ON ANY ELECTRONIC COPIES.

R.S	APPROVED
DRAWN	SCALE
DATE	

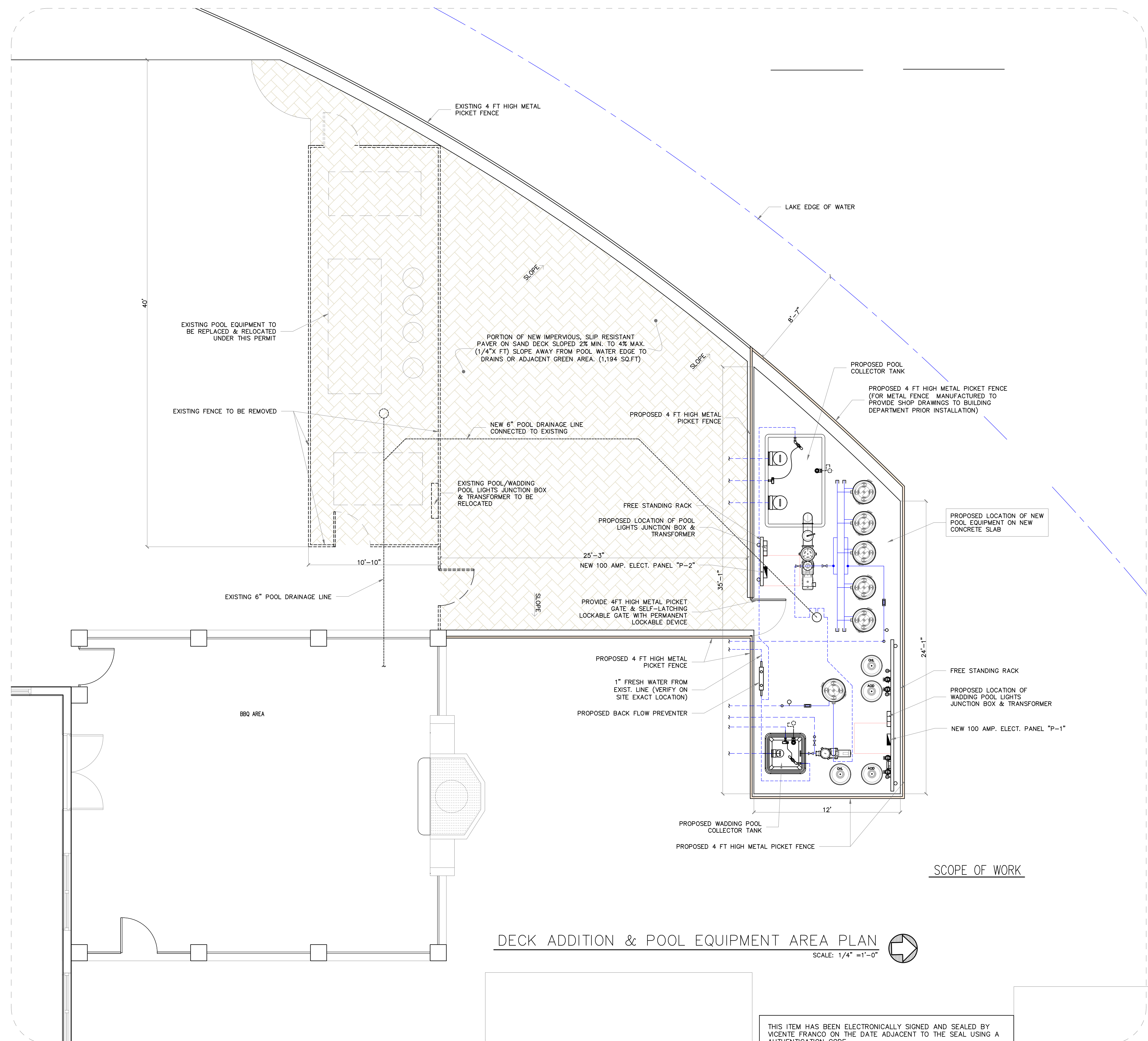

DECK ADDITION & POOL EQUIPMENT AREA PLAN

SCALE: 1/4" = 1'-0"

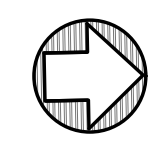

THIS ITEM HAS BEEN ELECTRONICALLY SIGNED AND SEALED BY VICENTE FRANCO ON THE DATE ADJACENT TO THE SEAL USING A AUTHENTICATION CODE.

PRINTED COPIES OF THIS DOCUMENT ARE NOT CONSIDERED SIGNED AND SEALED AND THE AUTHENTICATION CODE MUST BE VERIFIED ON ANY ELECTRONIC COPIES.

R.S	APPROVED
DRAWN	SCALE
DATE	

PLUMBING NOTES:

1. ALL POOL EQUIPMENT PIPING SHALL BE SCHEDULE 40, PVC-PW, NON-THREADED, NSF APPROVED SUPPORTED CONTINUOUSLY ON GROUND OR ON MAXIMUM 4'-0" CENTERS WITH CLEVIS HANGERS.
2. POOL WATER DISPOSAL SHALL BE IN ACCORDANCE WITH LOCAL BUILDING DEPARTMENT REQUIREMENTS.
3. ANTI VORTEX MAIN DRAINS SHALL HAVE ITS PLATE SECURELY FASTENED WITH TAMPERPROOF SCREWS.
4. POOL VACUUM SHALL HAVE SPRING LOADED CAP IN ACCORDANCE WITH THE FLORIDA BUILDING CODE.
5. ALL PIPING SHALL BE INSTALLED IN ACCORDANCE WITH THE FLORIDA BUILDING CODE-PLUMBING SECTION 309 AS IT PERTAINS TO BUOYANCY.
6. THE WATER VELOCITY THROUGH ALL SUCTION PIPING SHALL BE LESS THAN 6 FEET PER SECOND.
7. THE WATER VELOCITY THROUGH ALL GRAVITY PIPING SHALL BE LESS THAN 3 FEET PER SECOND.
8. THE WATER VELOCITY THROUGH ALL PRESSURE PIPING SHALL BE LESS THAN 10 FEET PER SECOND.
9. ALL PIPING SHALL BE SUITABLE FOR EXPOSURE TO ULTRA VIOLET RADIATION AND NORMAL OPERATING TEMPERATURES.

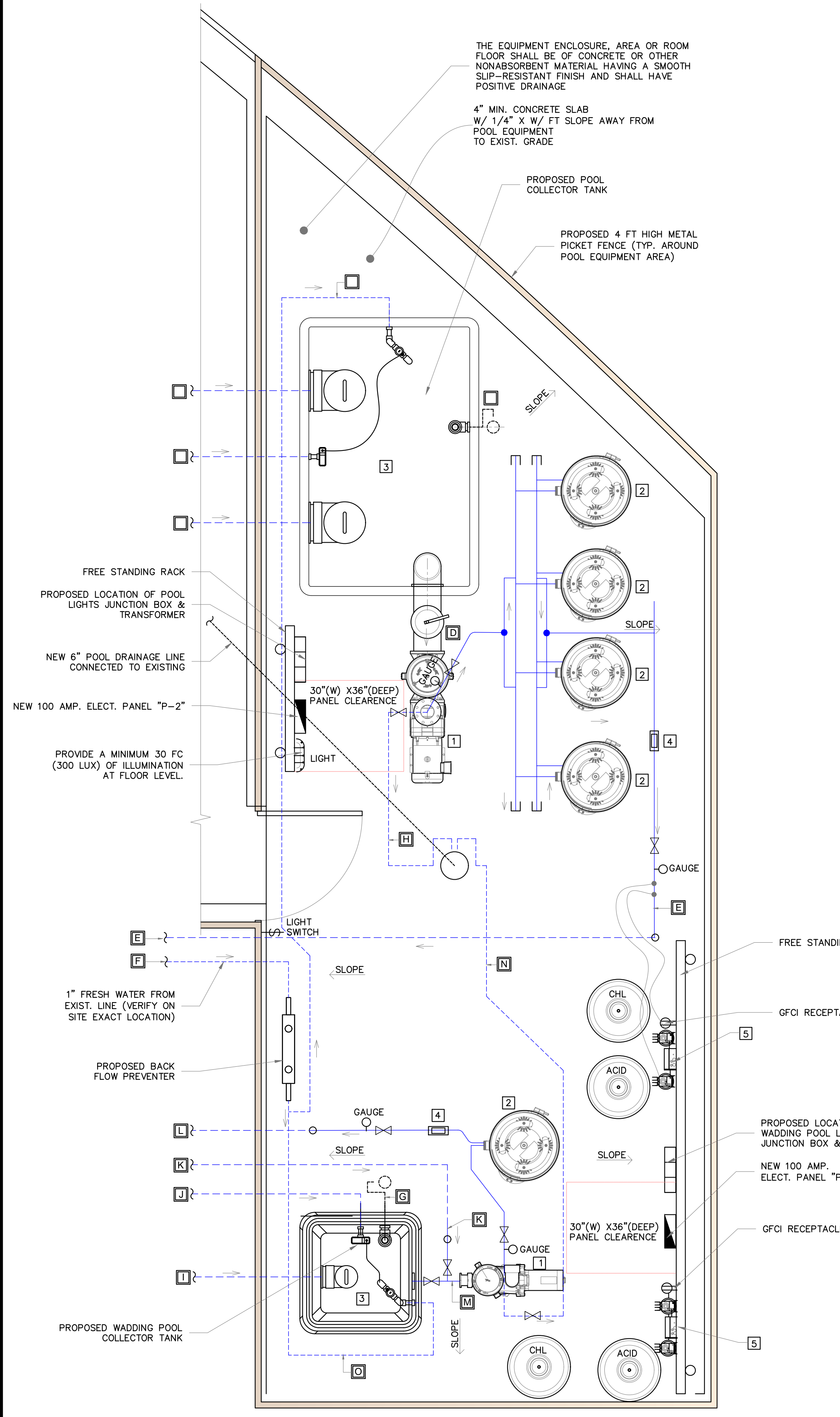

SWIMMING POOL

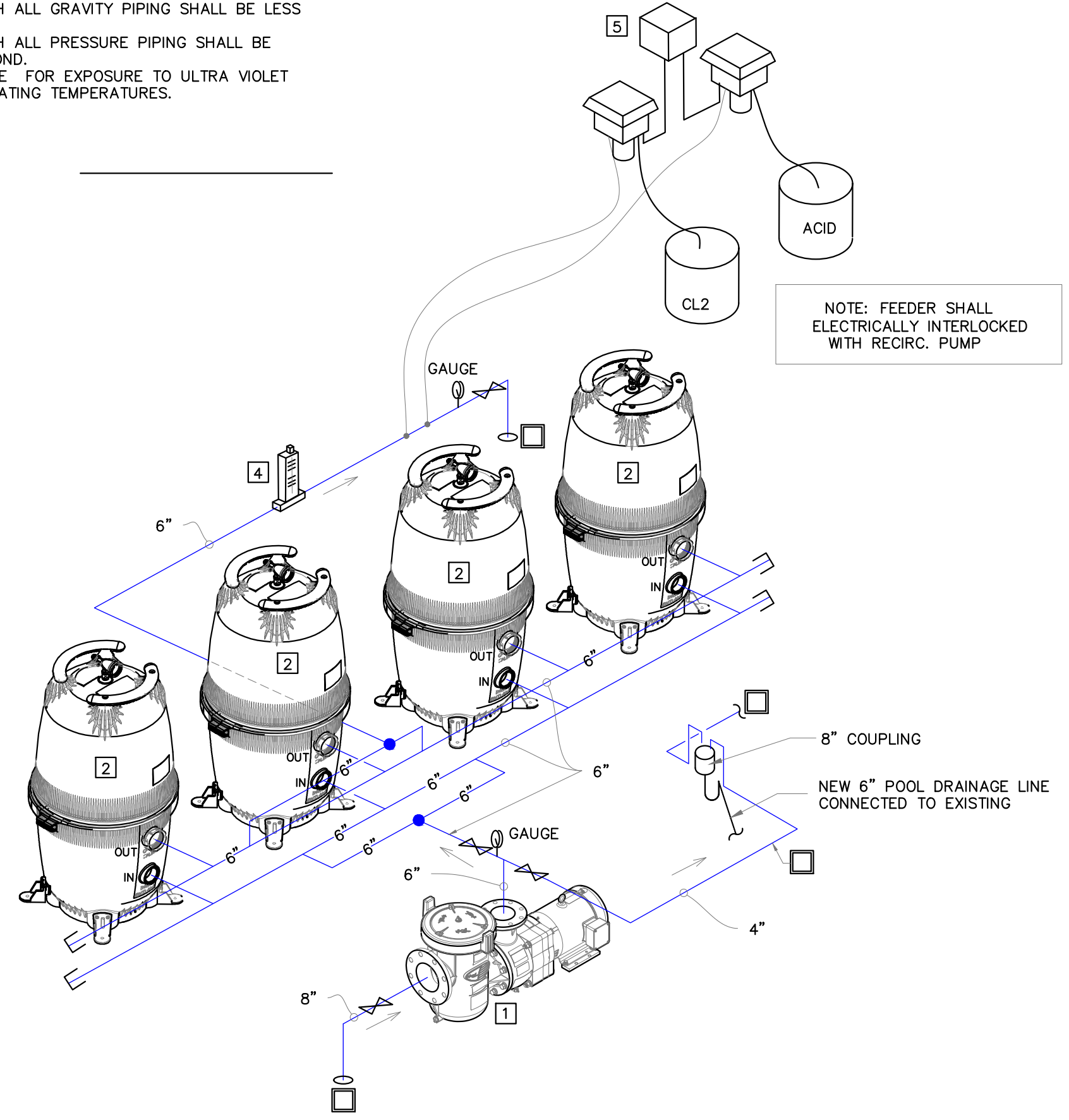

WADDING POOL

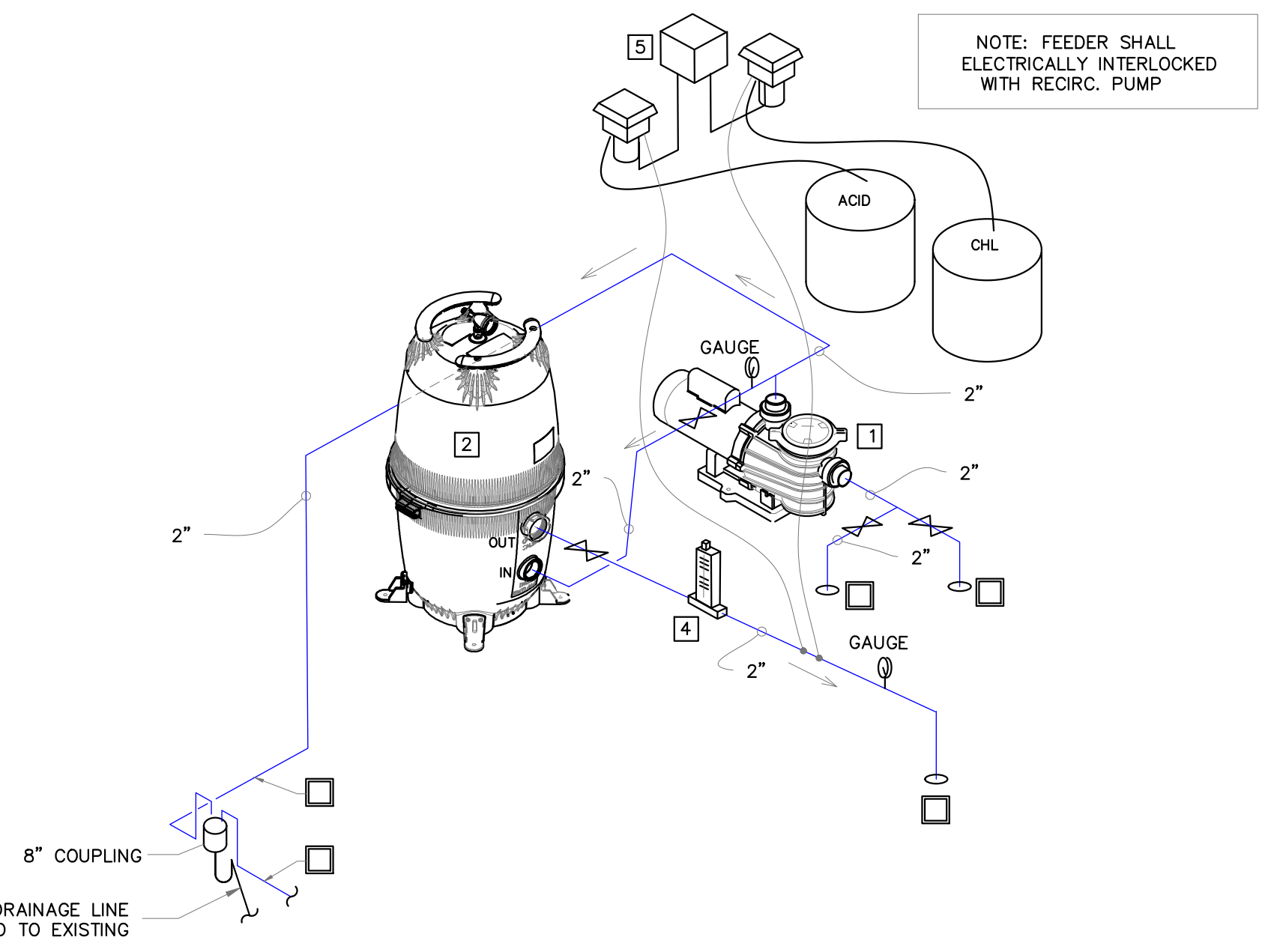

MARK	DESCRIPTION	QUANTITY
1	POOL PUMP 15 HP (3-PHASE) PENTAIR MOD: ECK 1500 WITH 680 GPM FLOW RATE AT 60 TDH (NSF/ ANSI 50 APPROVED)	-1-
2	PENTAIR CARTRIDGE FILTER MODEL: CQP520 WITH FILTRATION AREA OF 520 SQFT & FLOW RATE 195 GPM EACH (TOTAL FLOW RATE 780 GPM) (NSF/ ANSI 50 APPROVED)	-4-
3	AQUAWORX COLLECTOR TANK 1100 GAL	-1-
4	FLOW METER BY: BLUE-WHITE F-30800P (300 TO 2200 GPM), 8" PIPE SIZE FLOWMETER, F-300 SERIES (NSF/ ANSI 50 APPROVED)	-1-
5	MODEL 555017 UPC 7-5770600321-6 INCLUDES ONE (PH) ROLA-CHEM MODEL RC305 38 GPD PERISTALTIC PUMP AND ONE (CHL) ROLA-CHEM MODEL RC307 77 GPD PERISTALTIC PUMP	-1-

MARK	DESCRIPTION	QUANTITY
1	PUMP MODEL: CHALLENGER CFI-N2-3/4F WITH 52 GPM FLOW RATE AT 60 TDH 3/4 HP /230 VOLT/SINGLE PHASE (NSF/ ANSI 50 APPROVED)	-1-
2	PENTAIR CARTRIDGE CQP320 W/ 320 SQFT FILTRATION AREA & FLOW CAPACITY 120 GPM (NSF/ ANSI 50 APPROVED)	-5-
3	AQUAWORX COLLECTOR TANK 125 GAL	-1-
4	FLOW METER BLUE-WHITE MODEL: F-30200 P WITH FLOW (40-150 GPM) (NSF/ ANSI 50 APPROVED)	-1-
5	MODEL 555017 UPC 7-5770600321-6 INCLUDES ONE (PH) ROLA-CHEM MODEL RC303 12 GPD PERISTALTIC PUMP AND ONE (CHL) ROLA-CHEM MODEL RC305 38 GPD PERISTALTIC PUMP	-1-

THIS ITEM HAS BEEN ELECTRONICALLY SIGNED AND SEALED BY VICENTE FRANCO ON THE DATE ADJACENT TO THE SEAL USING A AUTHENTICATION CODE.

PRINTED COPIES OF THIS DOCUMENT ARE NOT CONSIDERED SIGNED AND SEALED AND THE AUTHENTICATION CODE MUST BE VERIFIED ON ANY ELECTRONIC COPIES.

R.S. DRAWN APPROVED
DATE SCALE

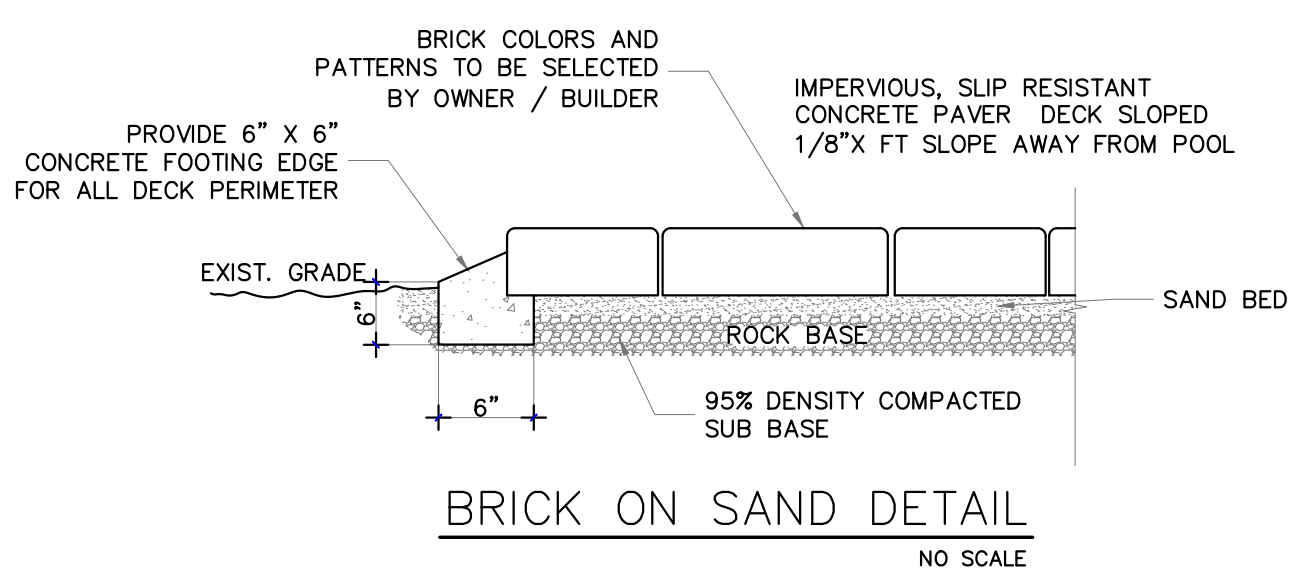
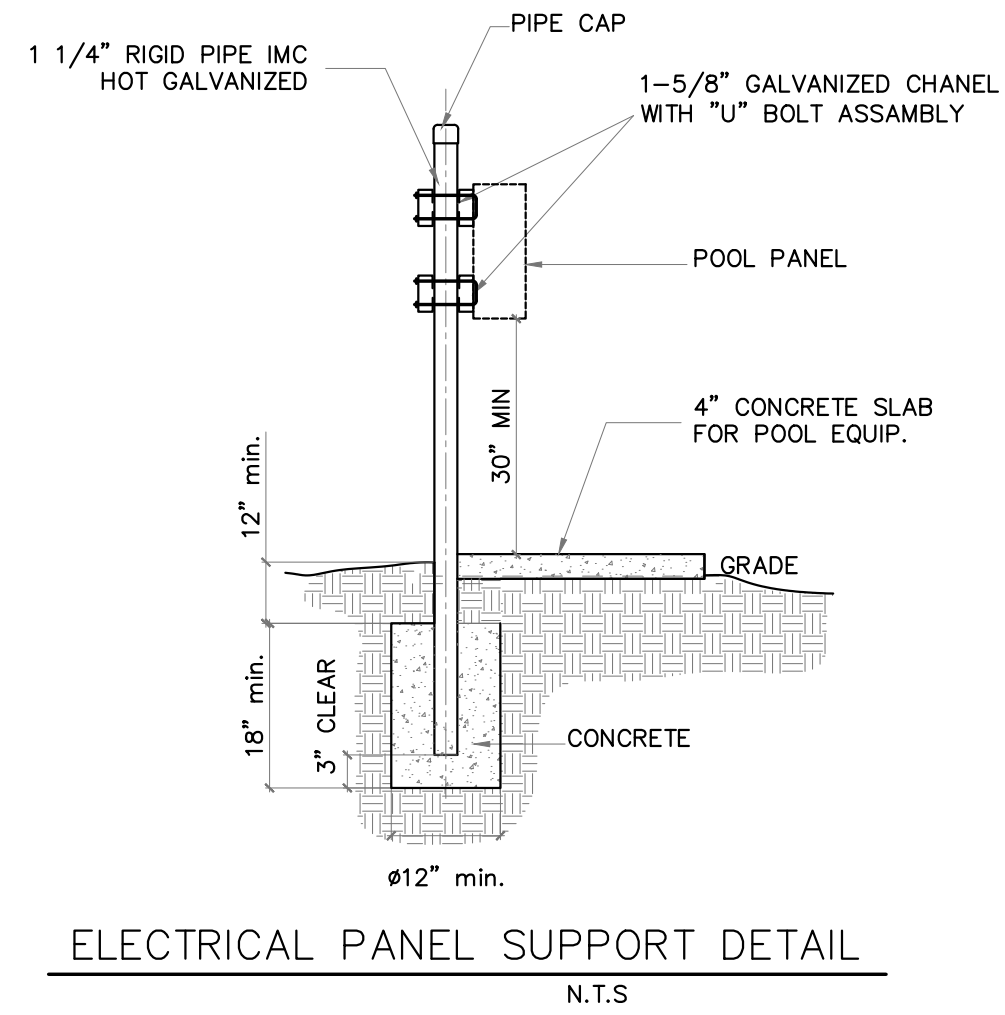
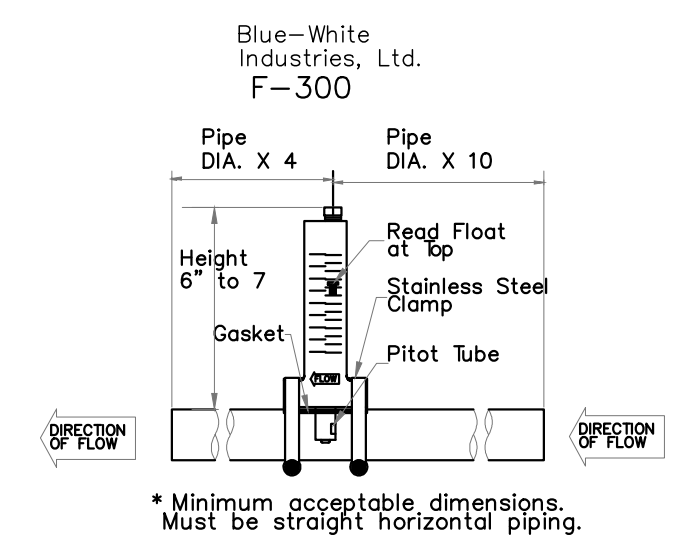
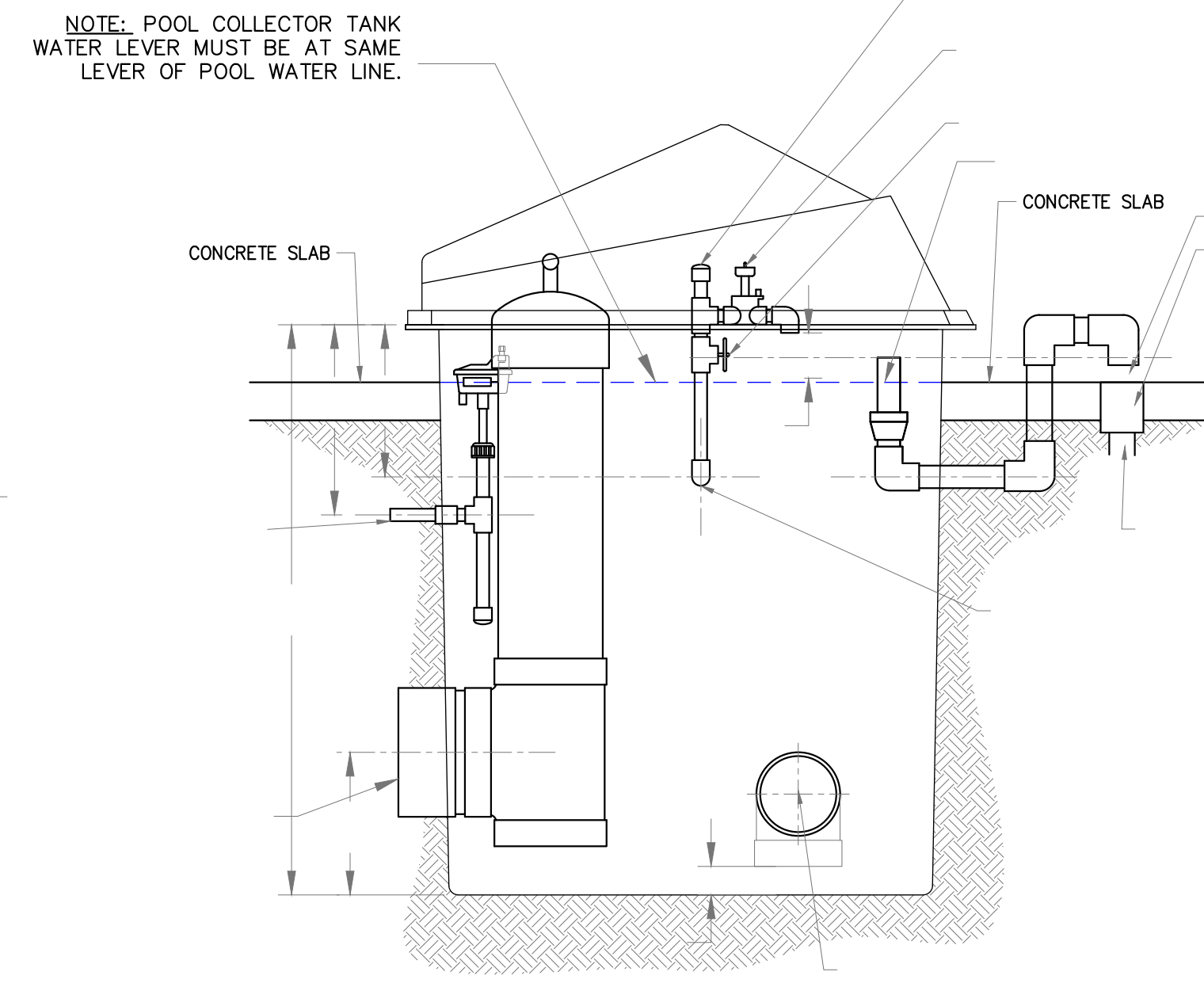
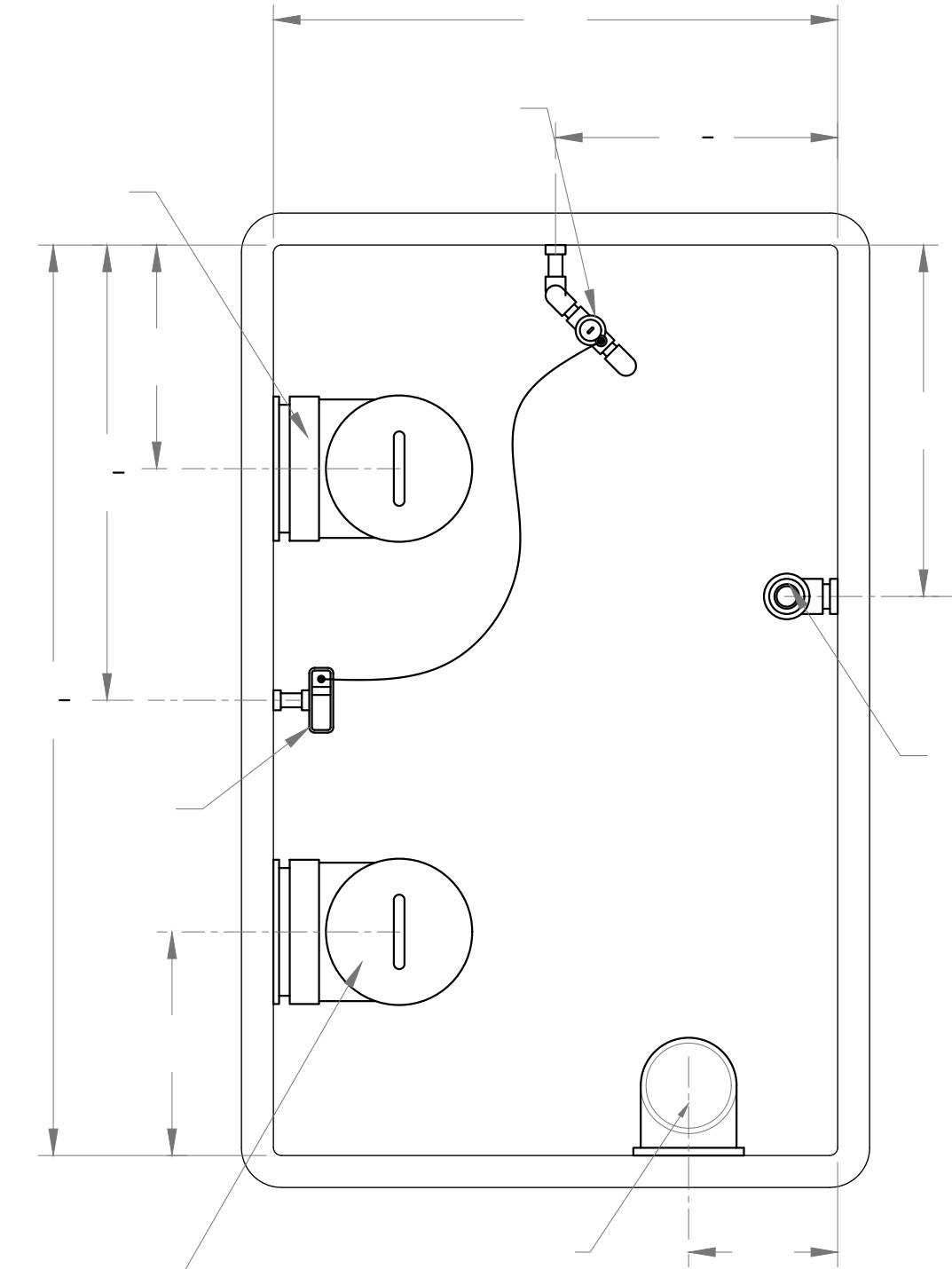
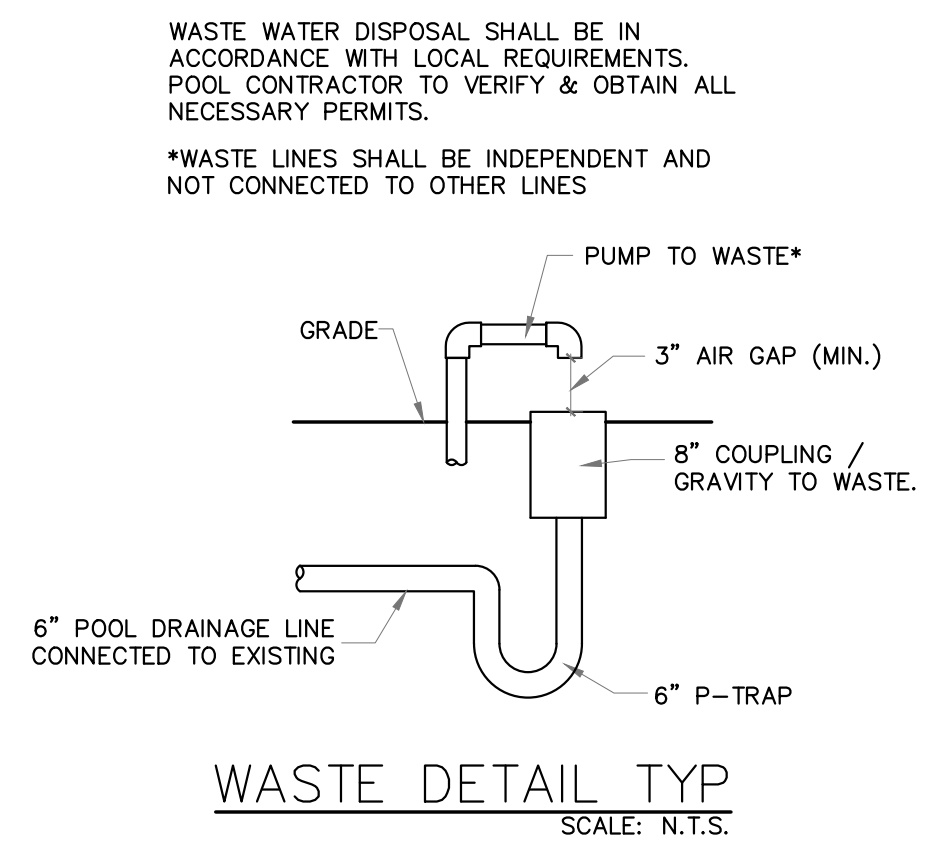
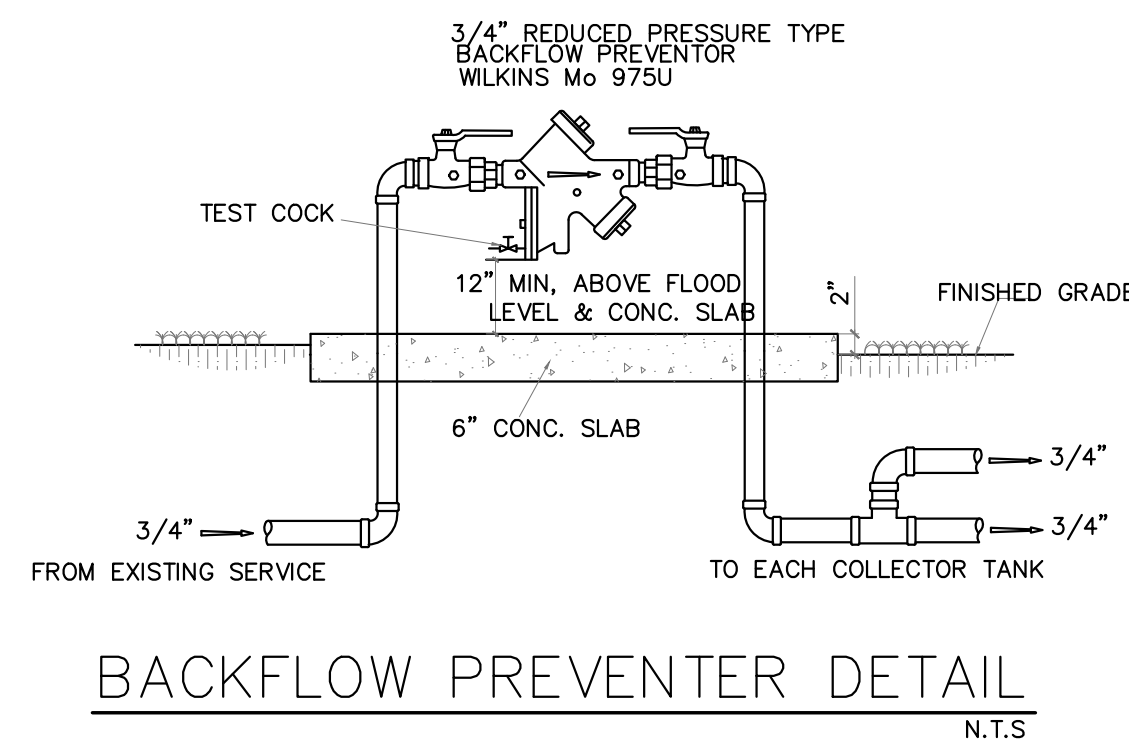

**AQUAWORX 1100 GALLONS
POOL COLLECTOR TANK DETAIL**
SCALE: N.T.S.

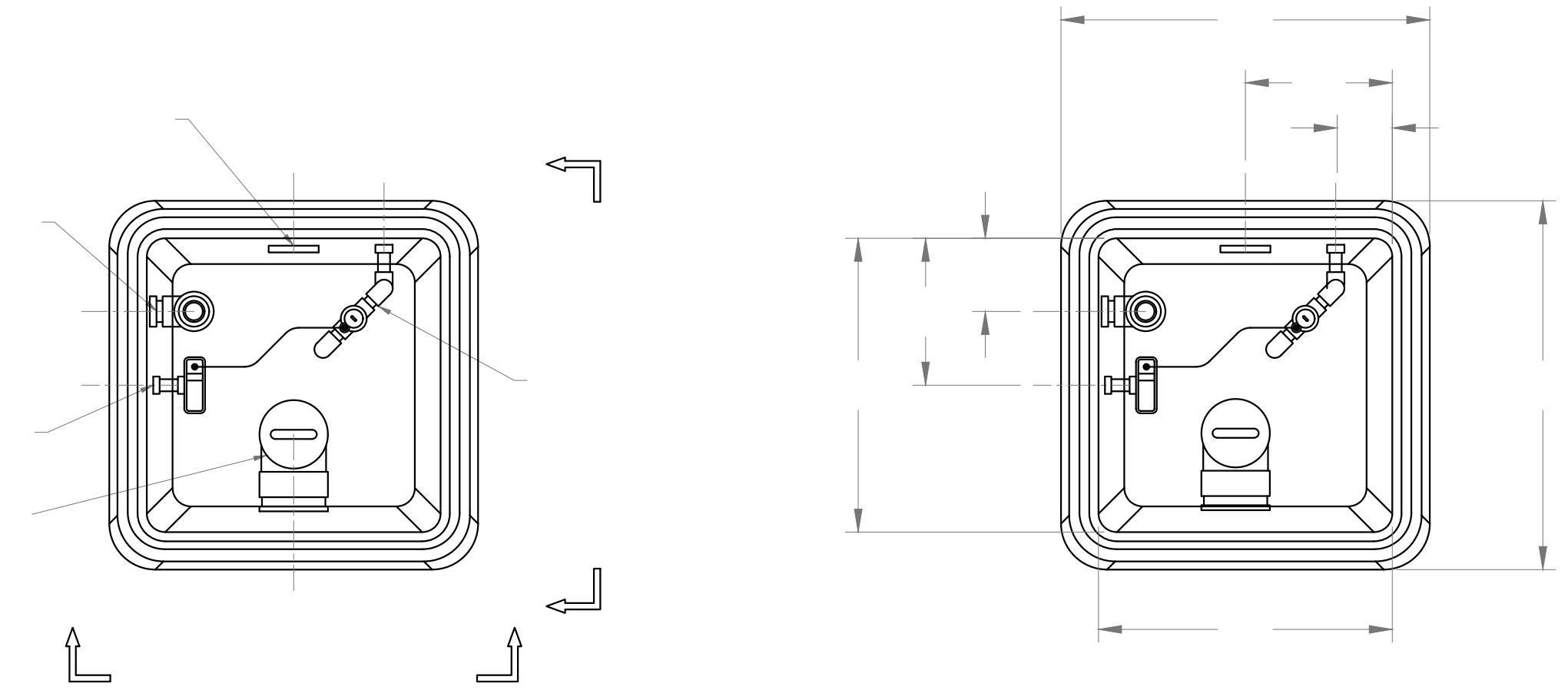

AQUAWORX

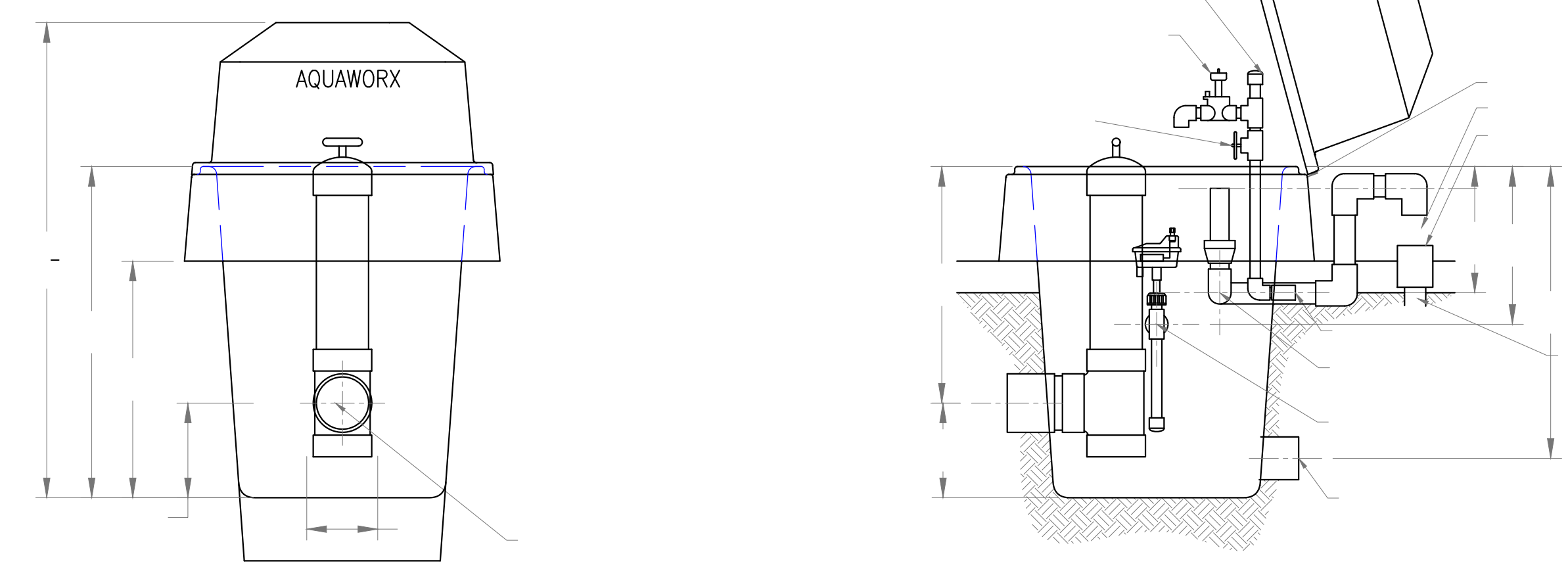
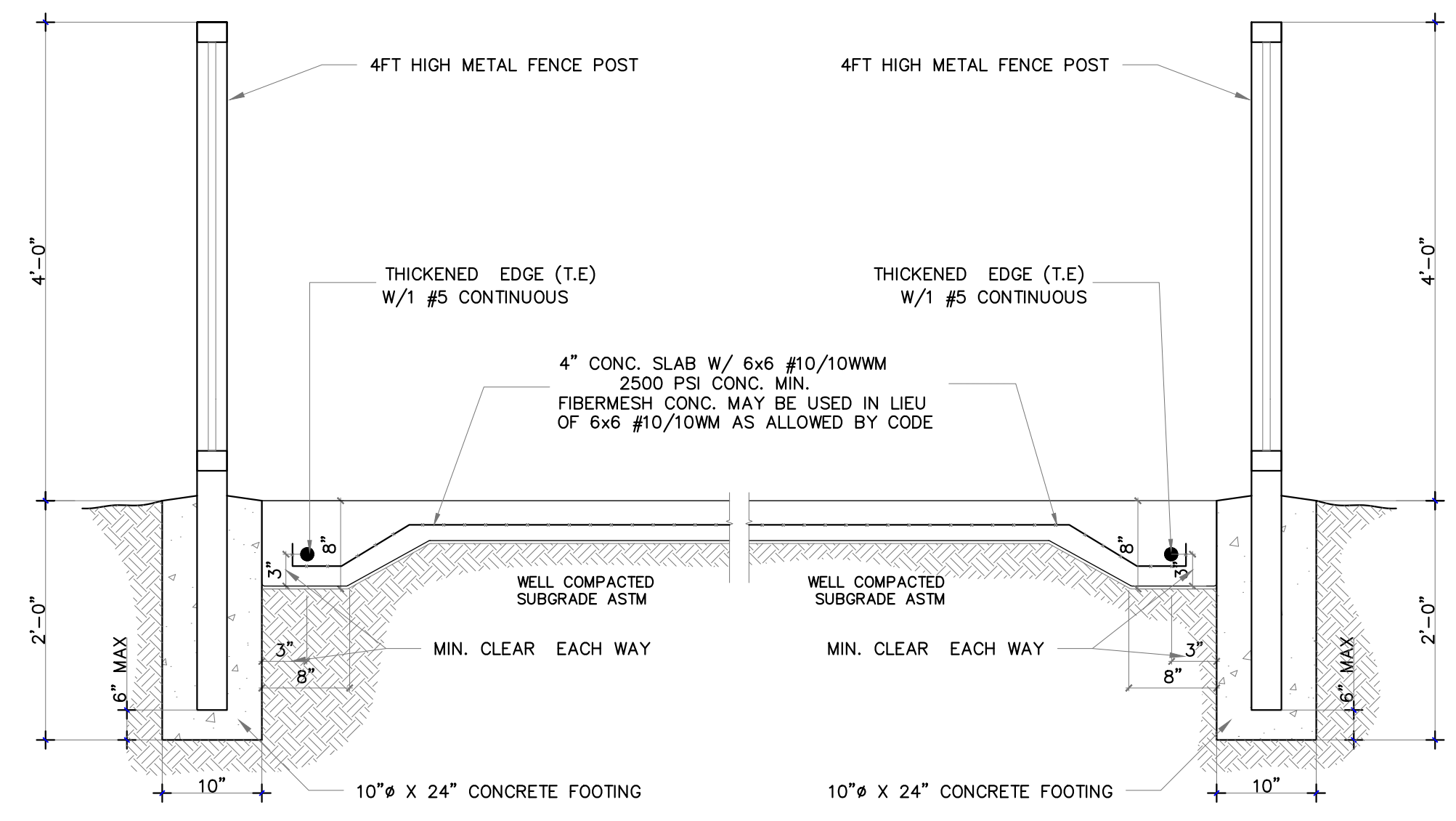

**AQUAWORX 125 GALLONS
WADING POOL COLLECTOR TANK DETAIL**

POOL EQUIPMENT CONCRETE SLAB DETAIL
scale: N.T.S.

THIS ITEM HAS BEEN ELECTRONICALLY SIGNED AND SEALED BY VICENTE FRANCO ON THE DATE ADJACENT TO THE SEAL USING A AUTHENTICATION CODE.

PRINTED COPIES OF THIS DOCUMENT ARE NOT CONSIDERED SIGNED AND SEALED AND THE AUTHENTICATION CODE MUST BE VERIFIED ON ANY ELECTRONIC COPIES.

R.S.	APPROVED
DRAWN	SCALE
DATE	

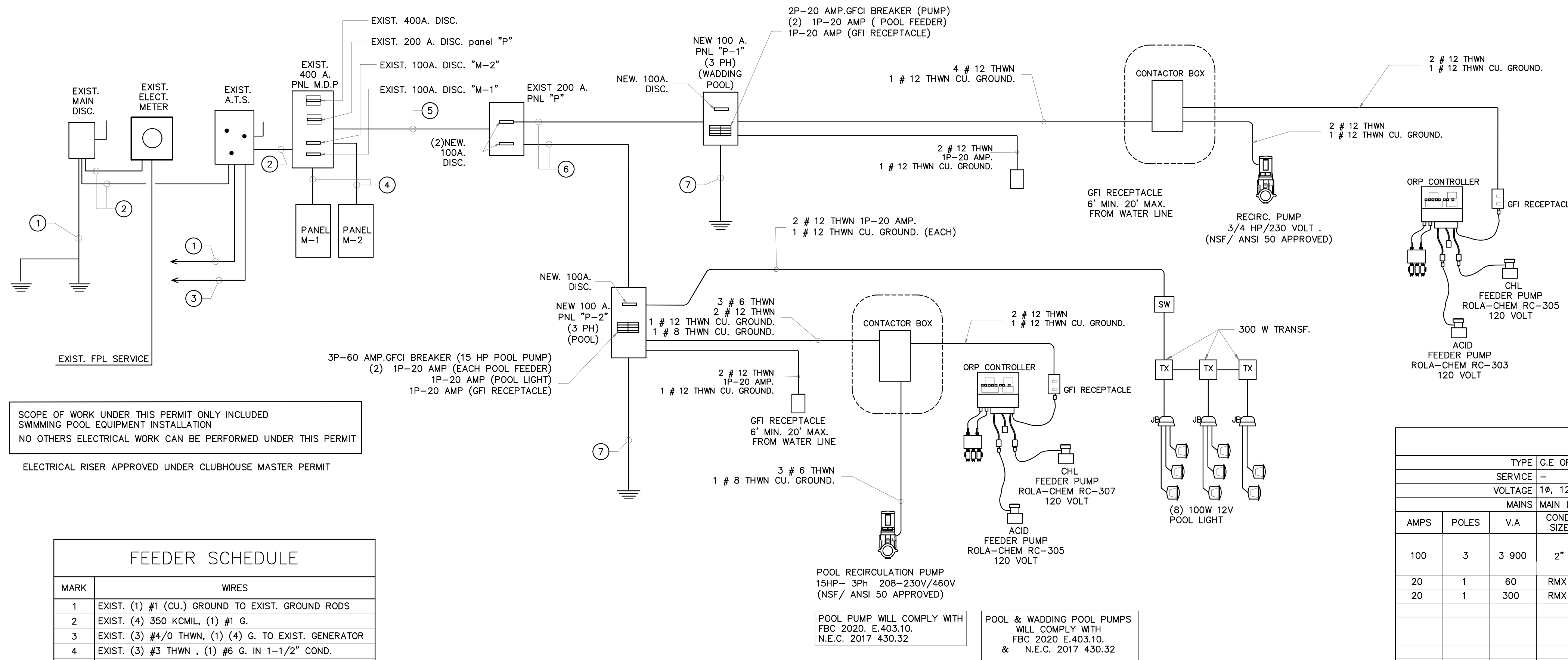

SCOPE OF WORK UNDER THIS PERMIT ONLY INCLUDED SWIMMING POOL EQUIPMENT INSTALLATION NO OTHERS ELECTRICAL WORK CAN BE PERFORMED UNDER THIS PERMIT
ELECTRICAL RISER APPROVED UNDER CLUBHOUSE MASTER PERMIT

MARK	WIRES
1	EXIST. (1) #1 (CU.) GROUND TO EXIST. GROUND RODS
2	EXIST. (4) 350 KCMIL (1) #1 G.
3	EXIST. (3) #4/0 THWN, (1) (4) G. TO EXIST. GENERATOR
4	EXIST. (3) #3 THWN, (1) #6 G. IN 1-1/2" COND.
5	EXIST. (4) #2/0 THWN, 1#6 G. IN 3" COND.
6	NEW (4) #3 THWN CU, 1#6 G. IN 2" COND.
7	NEW (1) #6 (Cu) G. IN 1/2" COND.

ELECTRICAL PANEL 'P'													
TYPE		G.E OR EQUAL		ENCLOSURE		NEMA 3R		LOCATION		SEE PLAN			
SERVICE		-		RATING		200 A		AC 10 K					
VOLTAGE		1Ø, 120/240		WIRE SIZE		COND. SIZE		V.A		POLES			
AMPS	POLES	V.A	COND. SIZE	WIRE SIZE	DESCRIPTION	CKT NO.	CKT NO.	DESCRIPTION	WIRE SIZE	COND. SIZE	V.A	POLES	AMPS
						1	2						
100	3	3 900	2"	3	PANEL P-1	3	4	PANEL P-2	3	2"	10 500	3	100
20	1	60	RMX	12	STORAGE LIGHT	7	8	STORAGE LIGHT	12	RMX	60	1	20
20	1	300	RMX	12	PARKING LIGHT	9	10						
						11	12						
						13	14						
						15	16						
						17	18						
						19	20						
						21	22						
						23	24						
TOTAL V.A		4 260		TOTAL V.A		10 560							
TOTAL LOAD @ 100%		14 820 W / 208 VOLT = 71.25 AMP											

ELECTRICAL RISER DIAGRAM

ELECTRICAL NOTES:

- ALL POOL ELECTRICAL WORK SHALL BE ACCOMPLISHED IN COMPLIANCE WITH FBC 2020, 7TH EDITION, CHAPTER 45
- ALL POOL ELECTRICAL WORKS, GROUNDING AND BONDING MUST BE CONFORM WITH THE NEC 2017, ART. 680
- AT LEAST ONE GFCI PROTECTED, 125-VOLT RECEPTACLE OUTLET IS REQUIRED BETWEEN 6 AND 20 FEET OF THE INSIDE WALL OF THE POOL. NEC 680.22(A)(1)(RESIDENTIAL AND COMMERCIAL)
- THE EQUIPMENT GROUNDING CONDUCTOR MUST BE A MINIMUM 12 AWG COPPER. NEC 680.21(A)(1); 680.23(F)(2); 680.25(B)(1)
- EQUIPOTENTIAL BONDING TO COMPLY WITH 2017 NEC 680.26(B) SHALL BE INSTALLED IN OR UNDER PAVED WALKING SURFACES FOR THREE FEET HORIZONTALLY BEYOND THE WALLS OF THE POOL. NEC 680.26(C) [4 POINTS & DECK BONDING (360 DEGREES)]
- RECEPTACLE OUTLETS ARE NOT PERMITTED WITHIN 6 FEET OF THE INSIDE WALLS OF A POOL. NEC 680.22(A)(2)
- POOL PUMP MOTOR CIRCUITS, MUST BE PROVIDED WITH GFCI PROTECTION. NEC 680.21(C)
- LIGHTING OUTLETS MUST BE LOCATED A MINIMUM OF 5 FEET FROM THE INSIDE WALL OF A POOL OR MOUNTED A MINIMUM OF 12 FEET ABOVE THE MAXIMUM WATER LEVEL. NEC 680.22(B)(1.)
- OVERHEAD CONDUCTORS ARE NOT PERMITTED OVER THE POOL OR WITHIN 10 FEET HORIZONTALLY FROM THE EDGE OF THE POOL. FBC 424.1.4.2.4
- OVERHEAD CONDUCTORS SHALL NOT BE PERMITTED OVER THE POOL OR WITHIN 10 FEET HORIZONTALLY FROM THE EDGE OF THE POOL UNLESS PROVIDED WITH CLEARANCE TO COMPLY WITH NEC 680.6.
- A CONDUCTIVE ELEMENT THAT IS PART OF THE POOL BONDING SYSTEM MUST BE IN DIRECT CONTACT WITH THE POOL WATER. IN THE ABSENCE OF RAILS, LADDERS OR NICHES, A WATER BONDING SHALL MEET THE REQUIREMENT. NEC 680.26(C)
- ALL METAL PARTS WITHIN 5 FEET OF THE POOL MUST BE BONDED TO A COMMON BONDING GRID. NEC 680.26(B)(5)
- UNDERWATER LIGHTING: UNDERWATER LUMINAIRES SHALL COMPLY WITH CHAPTER 27 OF THE FLORIDA BUILDING CODE.
- OVERHEAD WIRING: OVERHEAD SERVICE WIRING SHALL NOT PASS WITHIN AN AREA EXTENDING A DISTANCE OF 10 FEET (3,048 MM) HORIZONTALLY AWAY FROM THE INSIDE EDGE OF THE POOL WALLS, DIVING STRUCTURES, OBSERVATION STANDS, TOWERS OR PLATFORMS.

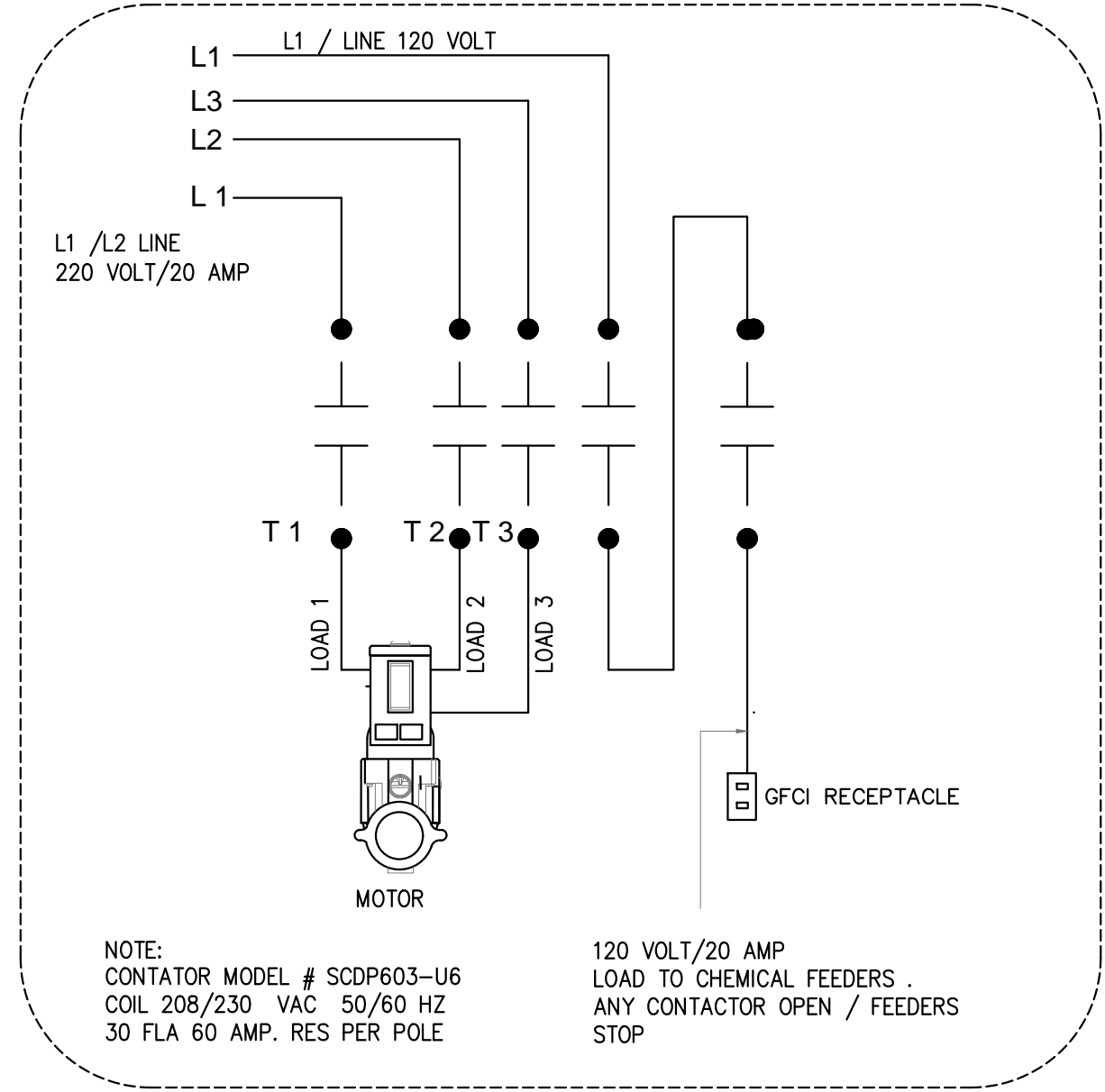

CONTACTOR WIRING DIAGRAM

ELECTRICAL PANEL 'P-1' (WADDING POOL)													
MANUFACTURER		SIEMENS		VOLTAGE		120/208 VAC 3Ø 4W		BUS RATING		100A AIC 65KA			
TYPE		PANELBOARD		LOCATION		POOL EQUIPMENT AREA		NEUTRAL		FULL			
AMPS	POLES	V.A	COND. SIZE	WIRE SIZE	DESCRIPTION	CKT NO.	CKT NO.	DESCRIPTION	WIRE SIZE	COND. SIZE	V.A	POLES	AMPS
20	2	1500	1/2"	12	WADDING POOL RECIRC. PUMP 3/4 HP	1	2	ACID FEEDER PUMP	12	1/2"	2400	1	20
						3	4						
						5	6						
						7	8						
						9	10						
						11	12				0		
						13	14				0		
						15	16				0		
						17	18				0		
						19	20						
TOTAL V.A		1,500		TOTAL V.A		2,400							
TOTAL LOAD @ 100%		3,900 W		18.75 AMP.									

- VIA TIME SWITCH AND/OR LIGHT CONTACTOR.
- ▲ PROVIDE GFI TYPE BREAKER.

ELECTRICAL PANEL 'P-2' (POOL)													
MANUFACTURER		SIEMENS		VOLTAGE		120/208 VAC 3Ø 4W		BUS RATING		100A AIC 65KA			
TYPE		PANELBOARD		LOCATION		POOL EQUIPMENT AREA		NEUTRAL		FULL			
AMPS	POLES	V.A	COND. SIZE	WIRE SIZE	DESCRIPTION	CKT NO.	CKT NO.	DESCRIPTION	WIRE SIZE	COND. SIZE	V.A	POLES	AMPS
60	3	7300	1"	3	POOL RECIRC. PUMP 15 HP	1	2	ACID FEEDER PUMP	12	1/2"	2400	1	20
						3	4						
						5	6	POOL LIGHT	12	1/2"	800	1	20
						7	8						
						9	10						
						11	12				0		
						13	14				0		
						15	16				0		
						17	18				0		
						19	20						
TOTAL V.A		7,300		TOTAL V.A		3,200							
TOTAL LOAD @ 100%		10,500 W		60.09 A									

- VIA TIME SWITCH AND/OR LIGHT CONTACTOR.
- ▲ PROVIDE GFI TYPE BREAKER.

THIS ITEM HAS BEEN ELECTRONICALLY SIGNED AND SEALED BY VICENTE FRANCO ON THE DATE ADJACENT TO THE SEAL USING A AUTHENTICATION CODE.

PRINTED COPIES OF THIS DOCUMENT ARE NOT CONSIDERED SIGNED AND SEALED AND THE AUTHENTICATION CODE MUST BE VERIFIED ON ANY ELECTRONIC COPIES.

R.S
DRAWN APPROVED
DATE SCALE

STONEGATE
COMMUNITY DEVELOPMENT DISTRICT

4

Daniel Rom

To: Victor Castro
Subject: RE: Lake maintenance

From: afuhrman@allstatemanagement.com <afuhrman@allstatemanagement.com>

Date: Friday, January 26, 2024 at 9:35 AM

To: Victor Castro <manager@unusmgmt.com>

Subject: Lake maintenance

Good morning Victor,

Great meeting you in person yesterday. I have attached the original contract and some information about algae from our chief biologist Steve Montgomery. It should hopefully help explain to the residents and I would appreciate you sending some of the complaints as they come in. I will have our licensed applicator apply a product to try and speed up the decomposition process of the dead treated algae.

Our debris team will be out to remove the large object in that one lake. It's stuck in the lake bottom and requires a few people.

Andy Fuhrman
Vice President
954-382-9766 p
954-382-9770 f
afuhrman@allstatemanagement.com
www.allstatemanagement.com



Understanding Your Lake

“Algae Problem Or Resolved Issue?”



If you live on a lake in South Florida, you've probably encountered scenes like the ones pictured above (especially in summer months). “It’s unsightly.” “It’s a mess.” “I called about this before.” “Why hasn’t anyone done anything?” Although neither picture represents a desirable situation they are very different. The picture on the left represents a legitimate algae concern. The picture on the right is actually what the previous picture would look like after it has been treated. Algae are very simple plants and by nature are able to reproduce and grow very quickly. This is why blooms can seemingly show up overnight. Allstate has over 20 years of aquatic management experience and our applicators have a proven track record in dealing with nuisance algal growth. The misunderstanding of algae management often occurs AFTER it has been treated. Even though the accumulated mass of algae may have responded to treatment it still requires time to decompose and sink. The mats are naturally buoyant, and decomposition can create gas bubbles that become trapped under them, keeping them afloat. Once an applicator has treated an algal bloom it’s up to Mother Nature to finish the job. The only option for instant gratification is manual removal of the dead mats. While this is an option, it can be costly due to its time consuming nature and fees associated with disposal of collected material. This service is available, but not typically included in a standard contract. Dispatching applicators to treat material that is already dead keeps them from addressing other issues in your lakes. Your observations of the situation are extremely important in helping us address your lake issues efficiently. Algae requiring treatment will typically be bright or vivid green in color, and float high on the water. Already treated algae will be dull brown or tan, similar in color to cardboard or a paper bag. Treated algae will also sit lower in the water and portions of the mat may even be sinking. Allstate Resource Management takes pride in our commitment to customer satisfaction. We will always respond to your concerns and strive to help you better understand your lake and our role in its care.

Author: Stephen Montgomery, Allstate Resource Management

STONEGATE
COMMUNITY DEVELOPMENT DISTRICT

5

RESOLUTION 2024-01

A RESOLUTION OF THE BOARD OF SUPERVISORS OF THE STONEGATE COMMUNITY DEVELOPMENT DISTRICT IMPLEMENTING SECTION 190.006(3), FLORIDA STATUTES, AND REQUESTING THAT THE MIAMI-DADE COUNTY SUPERVISOR OF ELECTIONS BEGIN CONDUCTING THE DISTRICT'S GENERAL ELECTIONS; PROVIDING FOR COMPENSATION; SETTING FORTH THE TERMS OF OFFICE; AUTHORIZING NOTICE OF THE QUALIFYING PERIOD; AND PROVIDING FOR SEVERABILITY AND AN EFFECTIVE DATE

WHEREAS, the Stonegate Community Development District ("District") is a local unit of special-purpose government created and existing pursuant to Chapter 190, Florida Statutes, being situated entirely within Miami-Dade County, Florida; and

WHEREAS, the Board of Supervisors ("Board") of Stonegate Community Development District seeks to implement section 190.006(3), Florida Statutes, and to instruct the Miami-Dade County Supervisor of Elections ("Supervisor") to conduct the District's General Election ("Election").

NOW, THEREFORE, BE IT RESOLVED BY THE BOARD OF SUPERVISORS OF THE STONEGATE COMMUNITY DEVELOPMENT DISTRICT:

1. **GENERAL ELECTION SEATS.** Seat 1, currently held by Alberto Eiras, and Seat 5, currently held by Mariela Figueroa, are scheduled for the General Election in November 2024. The District Manager is hereby authorized to notify the Supervisor of Elections as to what seats are subject to General Election for the current election year, and for each subsequent election year.

2. **QUALIFICATION PROCESS.** For each General Election, all candidates shall qualify for individual seats in accordance with Section 99.061, *Florida Statutes*, and must also be a qualified elector of the District. A qualified elector is any person at least 18 years of age who is a citizen of the United States, a legal resident of the State of Florida and of the District, and who is registered to vote with the Miami-Dade County Supervisor of Elections. Campaigns shall be conducted in accordance with Chapter 106, *Florida Statutes*.

3. **COMPENSATION.** Members of the Board receive \$200 per meeting for their attendance and no Board member shall receive more than \$4,800 per year.

4. **TERM OF OFFICE.** The term of office for the individuals to be elected to the Board in the General Election is four years. The newly elected Board members shall assume office on the second Tuesday following the election.

5. **REQUEST TO SUPERVISOR OF ELECTIONS.** The District hereby requests the Supervisor to conduct the District’s General Election in November 2024, and for each subsequent General Election unless otherwise directed by the District’s Manager. The District understands that it will be responsible to pay for its proportionate share of the General Election cost and agrees to pay same within a reasonable time after receipt of an invoice from the Supervisor.

6. **PUBLICATION.** The District Manager is directed to publish a notice of the qualifying period for each General Election, in a form substantially similar to **Exhibit A** attached hereto.

7. **SEVERABILITY.** The invalidity or unenforceability of any one or more provisions of this Resolution shall not affect the validity or enforceability of the remaining portions of this Resolution, or any part thereof.

8. **EFFECTIVE DATE.** This Resolution shall become effective upon its passage.

PASSED AND ADOPTED THIS 6TH DAY OF FEBRUARY, 2024.

**STONEGATE COMMUNITY DEVELOPMENT
DISTRICT**

CHAIR/VICE CHAIR, BOARD OF SUPERVISORS

ATTEST:

SECRETARY/ASSISTANT SECRETARY

Exhibit A

**NOTICE OF QUALIFYING PERIOD FOR CANDIDATES FOR THE BOARD OF SUPERVISORS OF THE
STONEGATE COMMUNITY DEVELOPMENT DISTRICT**

Notice is hereby given that the qualifying period for candidates for the office of Supervisor of the Stonegate Community Development District will commence at noon on June 10, 2024, and close at noon on June 14, 2024. Candidates must qualify for the office of Supervisor with the Miami-Dade County Supervisor of Elections located at 2700 NW 87 Avenue, Doral, Florida 33172, (305) 499-8683. All candidates shall qualify for individual seats in accordance with Section 99.061, Florida Statutes, and must also be a qualified elector of the District. A qualified elector is any person at least 18 years of age who is a citizen of the United States, a legal resident of the State of Florida and of the District, and who is registered to vote with the Miami-Dade County Supervisor of Elections. Campaigns shall be conducted in accordance with Chapter 106, Florida Statutes.

The Stonegate Community Development District has two (2) seats up for election, specifically seats 1 and 5. Each seat carries a four-year term of office. Elections are nonpartisan and will be held at the same time as the general election on November 5, 2024, in the manner prescribed by law for general elections.

For additional information, please contact the Miami-Dade County Supervisor of Elections.

**District Manager
Stonegate Community Development District**

STONEGATE
COMMUNITY DEVELOPMENT DISTRICT

6

RESOLUTION 2024-02

A RESOLUTION OF THE BOARD OF SUPERVISORS OF THE STONEGATE COMMUNITY DEVELOPMENT DISTRICT PROVIDING FOR THE APPOINTMENT OF A RECORDS MANAGEMENT LIAISON OFFICER; PROVIDING THE DUTIES OF THE RECORDS MANAGEMENT LIAISON OFFICER; ADOPTING A RECORDS RETENTION POLICY; DETERMINING THE ELECTRONIC RECORD TO BE THE OFFICIAL RECORD; PROVIDING FOR SEVERABILITY; AND PROVIDING FOR AN EFFECTIVE DATE.

WHEREAS, the Stonegate Community Development District (the “District”) is a local unit of special-purpose government created and existing pursuant to Chapter 190, *Florida Statutes*; and

WHEREAS, Chapter 190, *Florida Statutes*, authorizes the District to adopt rules to govern the administration of the District and to adopt resolutions as may be necessary for the conduct of District business; and

WHEREAS, Section 257.36(5), *Florida Statutes*, requires the District to establish and maintain an active and continuing program for the economical and efficient management of records and to provide for the appointment of a records management liaison officer (“Records Management Liaison Officer”); and

WHEREAS, the District desires for the Records Management Liaison Officer to be an employee of the District or an employee of the District Manager; and

WHEREAS, the District desires to authorize the District’s records custodian to appoint a Records Management Liaison Officer, which may or may not be the District’s records custodian; and

WHEREAS, the District desires to prescribe duties of the Records Management Liaison Officer and provide for the assignment of additional duties; and

WHEREAS, the District’s Board of Supervisors (“Board”) finds that it is in the best interests of the District to adopt by resolution a records retention policy (the “Records Retention Policy”) for immediate use and application.

NOW, THEREFORE, BE IT RESOLVED BY THE BOARD OF SUPERVISORS OF THE STONEGATE COMMUNITY DEVELOPMENT DISTRICT, THAT:

SECTION 1. The District hereby authorizes the District’s records custodian to appoint a Records Management Liaison Officer and report such appointment to the appropriate State of Florida agencies. A Records Management Liaison Officer shall be an employee of the District or the District Manager. The Board, and the District’s records custodian, shall each have the individual power to remove the Records Management

Liaison Officer at any time for any reason. Immediately following the removal or resignation of a Records Management Liaison Officer, the District's records custodian shall appoint a replacement Records Management Liaison Officer.

SECTION 2. The duties of the Records Management Liaison Officer shall include the following:

- A. Serve as the District's contact with the Florida Department of State, State Library and Archives of Florida;
- B. Coordinate the District's records inventory;
- C. Maintain records retention and disposition forms;
- D. Coordinate District records management training;
- E. Develop records management procedures consistent with the Records Retention Policy, as amended as provided herein;
- F. Participate in the development of the District's development of electronic record keeping systems;
- G. Submit annual compliance statements;
- H. Work with the Florida Department of State, State Library and Archives of Florida to establish individual retention schedules for the District, from time to time and as may be necessary; and
- I. Such other duties as may be assigned by the Board or the District's records custodian in the future.

SECTION 3. The District hereby adopts as its Records Retention Policy the applicable provisions of Section 257.36(5), *Florida Statutes*, the rules adopted by the Division of Library and Information Services of the Department of State ("Division") pursuant to Section 257.36, *Florida Statutes*, and the General Records Schedules established by the Division. However, the District will retain certain records longer than required by the General Records Schedules established by the Division as set forth in Exhibit A. To the extent the above statute, rules or schedules are amended or supplemented in the future, the District's Records Retention Policy shall automatically incorporate such amendment or supplement provided that such automatic amendment shall not reduce the retention times set forth in Exhibit A. The Records Retention Policy shall remain in full force and effect until such time as the Board amends the Policy.

SECTION 4. In accordance with Section 668.50, Florida Statutes, and Section 119.01, Florida Statutes, the Board finds that the electronic record shall be considered

the official record and any paper originals are hereby duplicates which may be disposed of unless required to be preserved by any applicable statute, rule or ordinance.

SECTION 5. If any provision of this resolution is held to be illegal or invalid, the other provisions shall remain in full force and effect.

SECTION 6. This Resolution shall become effective upon its passage; shall replace, supplant, and supersede any prior policy or resolution of the District regarding records retention; and shall remain in effect unless rescinded or repealed.

PASSED AND ADOPTED at a meeting of the District Board of Supervisors, this 6th day of February, 2024.

ATTEST:

**STONEGATECOMMUNITY DEVELOPMENT
DISTRICT**

Print name: _____
Secretary / Assistant Secretary

Print name: _____
Chairperson, Board of Supervisors

Exhibit A: Amendments to General Records Schedules Established by the Division

Exhibit A

Amendments to General Records Schedules established by the Division

ADVERTISEMENTS: LEGAL (Item #25)

The District shall retain mailed and published legal advertisements, and corresponding affidavits, relating to proceedings under uniform method of collection of debt assessments permanently. The District shall retain mailed and published legal advertisements, and corresponding affidavits, relating to the levy of assessments securing bonds for five (5) fiscal years provided applicable audits have been released, or until three (3) calendar years after related bonds are redeemed, whichever is later.

AUDITS: INDEPENDENT (Item #56)

The District shall retain the record copy of independent audits for ten (10) fiscal years or until three (3) calendar years after all related bonds are redeemed, whichever is later.

DISBURSEMENT RECORDS: DETAIL (Item #340)

The District shall retain the record copy of disbursement records relating to the use of bonds for five (5) fiscal years provided applicable audits have been released or until three (3) calendar years after related bonds are redeemed, whichever is later.

DISBURSEMENT RECORDS: SUMMARY (Item #341)

The District shall retain the record copy of disbursement records relating to the use of bonds for ten (10) fiscal years provided applicable audits have been released or until three (3) calendar years after related bonds are redeemed, whichever is later.

FINANCIAL REPORTS: LOCAL GOVERNMENT ANNUAL REPORTS (Item #107)

The District shall retain the record copy of disbursement records relating to the use of bonds for ten (10) fiscal years provided applicable audits have been released or until three (3) calendar years after all related bonds are redeemed, whichever is later.

INCIDENT REPORT FILES (Item #241)

The District shall retain incident reports for five (5) anniversary years from the date of the incident.

MINUTES: OFFICIAL MEETINGS (PRELIMINARY/AUDIO RECORDINGS/VIDEO RECORDINGS) (Item #4)

The District shall retain audio recordings of board of supervisor meetings for five (5) calendar years after adoption of the official minutes.

PROJECT FILES: CAPITAL IMPROVEMENT (Item #136)

The District shall retain the record copy of project files for projects funded with bonds for ten (10) fiscal years after completion of the project provided applicable audits have been released or until three (3) calendar years after all related bonds are redeemed, whichever is later.

REAL PROPERTY RECORDS: CONDEMNATION/DEMOLITION (Item #364)

The District shall retain the record copy of project files for condemnation/demolition projects funded with bonds for five (5) anniversary years after final action or until three (3) calendar years after all related bonds are redeemed, whichever is later. The record copy of deeds and easements shall be kept permanently.

REAL PROPERTY RECORDS: PROPERTY ACQUIRED (Item #172)

The District shall retain the record copy of documents related to property acquisitions funded with bonds for three (3) fiscal years after final disposition of the property provided applicable audits have been released or until three (3) calendar years after all related bonds are redeemed, whichever is later. The record copy of deeds and easements shall be kept permanently.

STONEGATE
COMMUNITY DEVELOPMENT DISTRICT

7

RESOLUTION 2024-03

A RESOLUTION OF THE BOARD OF SUPERVISORS OF THE STONEGATE COMMUNITY DEVELOPMENT DISTRICT ESTABLISHING AN ELECTRONIC SIGNATURE POLICY, PROVIDING DISTRICT MANAGER WITH AUTHORITY AND RESPONSIBILITY FOR APPROVAL OF ELECTRONIC SIGNATURES AND IMPLEMENTATION OF CONTROL PROCESSES AND PROCEDURES TO ENSURE COMPLIANCE, INTEGRITY, AND SECURITY, IN ACCORDANCE WITH CHAPTER 688, FLORIDA STATUTES; AND PROVIDING FOR SEVERABILITY AND EFFECTIVE DATE.

WHEREAS, the Stonegate Community Development District (the “District”), is a local unit of special-purpose government established and existing in accordance with the Uniform Community Development District Act of 1980, Chapter 190, Florida Statutes, as amended (the “Act”); and

WHEREAS, the Board of Supervisors of the District (the “Board”) regularly directs the District Manager of the District to execute and accept certain documents on behalf of the District and it is customary for certain documents to be transmitted via electronic means endorsed with electronic signatures; and

WHEREAS, consistent with Chapter 688, Florida Statutes, the District is responsible for adopting and implementing control processes and procedures to ensure adequate integrity, security, confidentiality, and auditability of business transactions conducted using electronic commerce; and

WHEREAS, the District Board of Supervisors finds that it is in the best interest of the District to enact a policy pertaining to the use and receipt of electronic signatures.

NOW, THEREFORE, BE IT RESOLVED BY THE BOARD OF SUPERVISORS OF THE STONEGATE COMMUNITY DEVELOPMENT DISTRICT, AS FOLLOWS:

Section 1. The foregoing recitals are hereby incorporated as findings of fact of the Board.

Section 2. The Board hereby establishes and adopts the “Electronic Signature Policy,” as follows:

ELECTRONIC SIGNATURE POLICY

PURPOSE: The purpose of this policy is to establish and identify the criteria and requirements for the use and validation of electronic signatures on documents on behalf of and for District business in accordance with Chapter 688, Florida Statutes, “Electronic Signature Act”.

DEFINITIONS:

Electronic means technology having electrical, digital, magnetic, wireless, optical, electromagnetic or similar capabilities.

Electronic record means a record created, generated, sent, communicated, received, or stored by electronic means.

Electronic signature means any letters, characters, or symbols, manifested by electronic or similar means, or logically associated with a record and that is executed or adopted with the intent to sign the record.

Electronic transaction means a transaction that is conducted or performed, in whole or in part, by electronic means or electronic records.

Record means information that is inscribed on a tangible medium or that is stored in an electronic or other medium and that is retrievable in perceivable form.

POLICY: This policy applies to any Electronic transaction that is a replacement for or complement to handwritten signatures on any record of or for the District, including, but not limited to, contracts, agreements, official minutes, bids, proposals and resolutions. Any Electronic record or Electronic signature may not be denied legal effect or enforceability solely because the record or signature is in electronic form. This policy does not limit the District’s right or option to require original signatures or Records in a non-electronic format as the District deems necessary or as required by applicable policies, laws or regulations.

PROCEDURE: When a document containing an Electronic signature is signed, transmitted and received the following requirements must be met:

1. The Electronic signature must establish sender/user authenticity. The electronic signing of a document by an individual must be accompanied by documentation that shows that the signer is the individual signing the document and the individual that has the authority to bind the entity entering into an agreement or contract with the District.
2. If a document has been modified or changed, the prior Electronic signature is invalid and said document requires another Electronic signature or shall be signed by hand. This is to prevent any issue that a document has been changed after it is signed.

3. The District Manager, or his or her designee, has the authority and responsibility for approval of any Electronic signature method utilized and shall be responsible for the implementation of control processes and procedures to ensure adequate integrity, security, confidentiality, and auditability of District business transactions conducted using electronic methods.

4. The Electronic signature shall include the entire name of the individual and shall be located on or near the signature block on the document being electronically signed.

5. The date of the Electronic signature must be captured, stored, and available for retrieval for the required retention period of the document executed.

6. The Electronic record must be transmitted to all parties in a format acceptable to the District Manager, or his or her designee.

Section 3. The District Manager is hereby directed to take all actions necessary and consistent with the intent of this Resolution.

Section 4. All resolutions or parts of resolutions in conflict herewith are repealed to the extent of such conflict.

Section 5. If any clause, section or other part or application of this Resolution is held by a court of competent jurisdiction to be unconstitutional, illegal or invalid, in part or as applied, it shall not affect the validity of the remaining portions or applications of this Resolution.

Section 6. The Resolution shall take effect immediately upon adoption.

PASSED AND ADOPTED THIS 6TH DAY OF FEBRUARY, 2024.

**STONEGATE COMMUNITY
DEVELOPMENT DISTRICT**

Print Name: _____
Secretary / Assistant Secretary

Print Name: _____
Chairman/Vice Chairman

STONEGATE
COMMUNITY DEVELOPMENT DISTRICT

8



Elections
2700 NW 87th Avenue
Miami, Florida 33172
T 305-499-8683 F 305-499-8547
TTY: 305-499-8480

miamidade.gov

June 9, 2023

Victor Castro
Stonegate CDD
1020 Malibu Way
Homestead, FL 33033

**Re: Club Malibu Bay
1020 Malibu Way**

Dear Mr. Castro:

Thank you for your continued partnership in allowing us the opportunity to use your facility during Federal, State, County, Municipal and Special elections.

Enclosed is an updated Polling Place Rental Agreement, which replaces your current agreement and authorizes the use of your facility as a polling location. Please review, forward the originally signed agreement to our office, and retain a copy for your records.

Attached is a copy of the 2023-2024 Election Calendars. Upon receipt of a signed and executed Polling Place Rental Agreement in conjunction with a scheduled election, a follow up letter will advise you of the need to use your facility as a polling location. Please note that this agreement may not be terminated by either party unless a written notice is received at least 45 days prior to said scheduled election.

Once again, thank you for your support and dedicated partnership. If you have any questions, please contact Erika Sierra-Trujillo, Deputy Supervisor of Elections, Operations Division at 305-499-8460.

Sincerely,

A handwritten signature in blue ink, appearing to read "Christina White".

Christina White
Supervisor of Elections

Enclosures

AGREEMENT

Miami-Dade County ("the County") and Owner/Designee, **Club Malibu Bay**, located at **1020 Malibu Way, Homestead, FL 33033**, agree to the following:

Owner's Obligation

Owner and/or his/her assignees, heirs or successors will permit Miami-Dade County to use approximately **1100** square feet of space in the **Club Malibu Bay** (the "Property") located at **1020 Malibu Way, Homestead, FL 33033**, for any federal, state, county, municipal or district election conducted.

Miami-Dade County Obligation

The County does hereby agree to indemnify and hold harmless, from any and all personal injury or property damage claims, liabilities, losses, and causes of action which may arise solely as a result of election operations conducted on the Property. This agreement is subject to the provisions of Section 768.28 Florida Statutes, such that the County shall not be held liable to pay a personal injury or property damage claim or judgment by any one person which exceeds the sum of \$200,000, or any claim or judgments or portions thereof, which, when totaled with all other occurrence, exceeds the sum of \$300,000 from any and all personal injury or property damage claims, liabilities, losses and causes of action which may arise solely as a result of election operations conducted on the Property. However, nothing herein shall be deemed to indemnify Owner from any liability or claim arising out of the negligent performance or failure of performance of the Owner or any unrelated third party.

Termination or Modification of Agreement

This agreement may be terminated by either party, after discussion with the other, by providing 45 days prior written notice.

Accepted and Approved By:

By: 
Christina White, Supervisor of Elections
(Pursuant to Resolution R-59-14)

Date

By: 
Signature: Property Owner/Designee

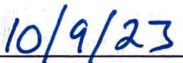
Date

Type or Print Name

Club Malibu Bay
1020 Malibu Way
Homestead, FL 33033

c: Baunie McConnell, Director of Risk Management
Risk Management Division, Internal Services Department

2023 Election Calendar

(subject to change)

Please note that Candidate Qualifying Dates are subject to change.
Questions about municipal elections must be directed to the [municipal clerk](#).

No elections scheduled for January

February 21 (Registration Closing - Jan. 23)

- Golden Beach General Election (Candidate Qualifying Dates: Jan. 02, 2023 - Jan. 9, 2023)

February 27 (Registration Closing - Jan. 30)

- Miami Special Election (Candidate Qualifying Dates: Jan. 9, 2023 - Jan. 13, 2023)

March 7 (Registration Closing - Feb. 6)

- Golden Beach Run-Off Election ****CANCELLED****
- Hialeah Gardens General Election (Candidate Qualifying Dates: Dec. 21, 2022 - Jan. 23, 2023) ****CANCELLED ****
- Pinecrest Special Election (Mail Ballot)

March 21 (Registration Closing - Feb. 21)

- Hialeah Gardens Run-Off Election ****CANCELLED ****

April 4 (Registration Closing - Mar. 6)

- Bay Harbor Islands General Election (Candidate Qualifying Dates: Feb. 23, 2023 - Mar. 3, 2023)
- Miami Springs General and Special Elections (Candidate Qualifying Dates: Dec. 19, 2022 - Feb. 17, 2023)

April 11 (Registration Closing - Mar. 13)

- Coral Gables General Biennial Election (Candidate Qualifying Dates: Feb. 20, 2023 - Feb. 24, 2023)
- Miami Shores Village Council and Special Elections (Candidate Qualifying Dates: Feb. 6, 2023 - Mar. 3, 2023)

April 25 (Registration Closing - Mar. 27)

- Coral Gables Run-Off Election

May 2 (Registration Closing - Apr. 3)

- Bal Harbour Village Special Election

May 4 (Registration Closing - Apr. 5)

- Bay Harbor Islands Run-Off Election ****CANCELLED****

May 9 (Registration Closing - Apr. 10)

- Miami Shores Village Council Run-Off Election ****CANCELLED****
- North Miami Regular Election (Candidate Qualifying Dates: Mar. 27, 2023 - Apr. 4, 2023) ****RESCHEDULED TO 2024****
- Sweetwater General Municipal Election (Candidate Qualifying Dates: Mar. 15, 2023 - Mar. 24, 2023)

May 23 (Registration Closing - Apr. 24)

- Sunny Isles Beach Special Election
- Sweetwater Run-Off Election ****CANCELLED****

June 6 (Registration Closing - May 8)

- North Miami Run-Off Election ****RESCHEDULED TO 2024****

No elections scheduled for July

No elections scheduled for August

September 12 (Registration Closing - Aug. 14)

- Virginia Gardens Municipal Election (Candidate Qualifying Dates: Jul. 14, 2023 - Aug. 14, 2023) ****RESCHEDULED TO 2024****

October 3 (Registration Closing - Sept. 5)

- Homestead Primary Election (Candidate Qualifying Dates: Aug. 28, 2023 - Sept. 1, 2023)

November 7 (Registration Closing - Oct. 10)

- Hialeah Primary Election (Candidate Qualifying Dates: July 10, 2023 - July 31, 2023)
- Homestead General Election
- Miami General Municipal Election (Candidate Qualifying Dates: Sept. 8, 2023 - Sept. 23, 2023)

- Miami Beach General Election (Candidate Qualifying Dates: Sept. 5, 2023 - Sept. 8, 2023)

November 21 (Registration Closing - Oct. 23)

- Hialeah General Election
- Miami Run-Off Election
- Miami Beach Run-Off Election

No elections scheduled for December

*When 29 days prior to registration closing date falls on a holiday, the date is moved to the next business day.

2024 Election Calendar

(subject to change)

Please note that Candidate Qualifying Dates are subject to change.
Questions about municipal elections must be directed to the [municipal clerk](#).

January 23 (Registration Closing Dec 26*)

- Florida City Biennial Election (Candidate Qualifying Dates: Nov. 29, 2023 - Dec. 8, 2023)

February 13 (Registration Closing Jan. 16*)

- Florida City Run-Off Election

February 20 (Registration Closing Jan. 22)

- Indian Creek Village General Election (Candidate Qualifying Dates: Jan. 03, 2024 - Jan. 17, 2024)

March 19 (Registration Closing Feb. 20*)

- **PRESIDENTIAL PREFERENCE PRIMARY ELECTION**
- Surfside General Municipal Election (Candidate Qualifying Dates: Jan. 15, 2024 - Feb 05, 2024)

April 02 (Registration Closing Mar. 4)

- Bay Harbor Islands General Election (Candidate Qualifying Dates: Feb. 22, 2024 - Mar. 03, 2024)
- Surfside Run-Off Election

April 09 (Registration Closing Mar. 11)

- West Miami Municipal Election (Candidate Qualifying Dates: Feb. 19, 2024 - Feb. 23, 2024)

April 30 (Registration Closing Apr. 01)

- Bay Harbor Islands Run-Off Election

No elections scheduled for May

No elections scheduled for June

No elections scheduled for July

August 20 (Registration Closing Jul. 22)

- PRIMARY ELECTION

- 2024 Ballot Issues Deadlines

- Key Biscayne Primary Election (Candidate Qualifying Dates: Jun. 04, 2024 - Jun. 14, 2024)
- Miami Gardens General Election (Candidate Qualifying Dates: TBD - TBD)

November 5 (Registration Closing Oct. 7)

- GENERAL ELECTION

- 2024 Ballot Issues Deadlines

- Aventura General Election (Candidate Qualifying Dates: Aug. 12, 2024 - Aug. 16, 2024)
- Bal Harbour Village General Election (Candidate Qualifying Dates: Aug. 12, 2024 - Aug. 16, 2024)
- Biscayne Park General Municipal Election (Candidate Qualifying Dates: Aug. 05, 2024 - Aug. 16, 2024)
- Cutler Bay General Election (Candidate Qualifying Dates: TBD - TBD)
- Doral General Election (Candidate Qualifying Dates: Jul. 08, 2024 - Jul. 12, 2024)
- El Portal General Election (Candidate Qualifying Dates: Aug. 05, 2024 - Aug. 15, 2024)
- Key Biscayne Municipal Election (Candidate Qualifying Dates: Aug. 12, 2024 - Aug. 22, 2024)
- Medley General Election (Candidate Qualifying Dates: Jul. 08, 2024 - Aug. 06, 2024)
- Miami Gardens Run-Off Election
- Miami Lakes General Election (Candidate Qualifying Dates: Jul. 29, 2024 - Aug. 07, 2024)
- North Bay Village General Election (Candidate Qualifying Dates: TBD - TBD)
- North Miami Regular Election (Candidate Qualifying Dates: TBD - TBD)
- North Miami Beach General Election (Candidate Qualifying Dates: Aug. 26, 2024 - Aug. 31, 2024)
- Opa-locka General Election (Candidate Qualifying Dates: Aug. 05, 2024 - Aug. 16, 2024)
- Palmetto Bay General Election (Candidate Qualifying Dates: Aug. 05, 2024 - Aug. 16, 2024)

- Pinecrest General Election (Candidate Qualifying Dates: Jun. 10, 2024 - Jun. 14, 2024)
- South Miami General Election (Candidate Qualifying Dates: Aug. 12, 2024 - Aug. 22, 2024)
- Sunny Isles Beach General Election (Candidate Qualifying Dates: Aug. 13, 2024 - Aug. 16, 2024)
- Virginia Gardens Municipal Election (Candidate Qualifying Dates: Sep. 6, 2024 - Oct. 07, 2024)

November 19 (Registration Closing Oct. 21)

- Bal Harbour Village Run-Off Election
- Biscayne Park Run-Off Election
- El Portal Run-Off Election
- North Bay Village Run-Off Election
- North Miami Beach Run-Off Election
- Pinecrest Run-Off Election

November 26 (Registration Closing Oct. 28)

- Medley Run-Off Election
- Miami Lakes Run-Off Election

December 03 (Registration Closing Nov. 04)

- Opa-locka Run-Off Election
- Palmetto Bay Run-Off Election
- South Miami Run-Off Election
- Sunny Isles Beach Run-Off Election

December 10 (Registration Closing Nov. 12*)

- Doral Run-Off Election

Date - TBD

- Cutler Bay Run-Off Election
- North Miami Run-Off Election

*When 29 days prior to registration closing date falls on a holiday, the date is moved to the next business day.

STONEGATE
COMMUNITY DEVELOPMENT DISTRICT

CONSENT
AGENDA

STONEGATE
COMMUNITY DEVELOPMENT DISTRICT

UNAUDITED
FINANCIAL
STATEMENTS

**STONEGATE
COMMUNITY DEVELOPMENT DISTRICT
FINANCIAL STATEMENTS
UNAUDITED
DECEMBER 31, 2023**

**STONEGATE
COMMUNITY DEVELOPMENT DISTRICT
BALANCE SHEET
GOVERNMENTAL FUNDS
DECEMBER 31, 2023**

	General Fund	Debt Service Fund 2013	Debt Service Fund 2020	Capital Projects Fund 2020	Total Governmental Funds
ASSETS					
Bank of America	\$ 1,945,157	\$ -	\$ -	\$ -	\$ 1,945,157
FineMark Bank - money mkt*	262,966	-	-	-	262,966
Investments					
State Board of Administration	12	-	-	-	12
Revenue 2013	-	101,106	-	-	101,106
Reserve 2013	-	25,000	-	-	25,000
Interest 2013	-	103	-	-	103
Sinking fund 2013	-	176	-	-	176
Prepayment 2013	-	33,291	-	-	33,291
Revenue 2020	-	-	218,484	-	218,484
Reserve 2020	-	-	159,500	-	159,500
Construction 2020	-	-	-	340,581	340,581
Undeposited funds	670	-	3,667	-	4,337
Due from other	141	-	-	-	141
Due from other funds					
General fund	-	307,996	165,226	-	473,222
Prepaid expense	20,872	-	-	-	20,872
Total assets	<u>\$ 2,229,818</u>	<u>\$ 467,672</u>	<u>\$546,877</u>	<u>\$ 340,581</u>	<u>\$ 3,584,948</u>
LIABILITIES AND FUND BALANCES					
Liabilities:					
Accounts payable	\$ 36,772	\$ -	\$ -	\$ -	\$ 36,772
Contracts payable	-	-	-	6,753	6,753
Due to other funds					
Debt service - series 2013	307,996	-	-	-	307,996
Debt service - series 2020	165,226	-	-	-	165,226
Deposits - rental facility	1,000	-	-	-	1,000
Total liabilities	<u>510,994</u>	<u>-</u>	<u>-</u>	<u>6,753</u>	<u>517,747</u>
Fund Balance					
Restricted					
Debt service	-	467,672	546,877	-	1,014,549
Construction	-	-	-	333,828	333,828
Committed					
Clubhouse renewal & replacement	155,000	-	-	-	155,000
Assigned					
3 months working capital	303,227	-	-	-	303,227
Disaster	225,000	-	-	-	225,000
Unassigned	1,035,597	-	-	-	1,035,597
Total fund balance	<u>1,718,824</u>	<u>467,672</u>	<u>546,877</u>	<u>333,828</u>	<u>3,067,201</u>
Total liabilities & fund balances	<u>\$ 2,229,818</u>	<u>\$ 467,672</u>	<u>\$546,877</u>	<u>\$ 340,581</u>	<u>\$ 3,584,948</u>

**STONEGATE
COMMUNITY DEVELOPMENT DISTRICT
STATEMENT OF REVENUES, EXPENDITURES,
AND CHANGES IN FUND BALANCES
GENERAL FUND
FOR THE PERIOD ENDED DECEMBER 31, 2023**

	Current Month	Year to Date	Budget	% of Budget
REVENUES				
Assessments	\$ 714,418	\$ 948,618	\$ 1,379,906	69%
Interest	1,295	3,502	1,000	350%
Clubhouse rental fees	-	-	2,000	0%
Miscellaneous	-	4,195	5,000	84%
Total revenues	<u>715,713</u>	<u>956,315</u>	<u>1,387,906</u>	69%
EXPENDITURES				
Administrative				
Supervisors	-	-	6,000	0%
Payroll taxes	-	-	459	0%
Management/recording/accounting	3,638	10,914	43,655	25%
Legal	400	1,253	20,000	6%
Engineering	126	126	10,000	1%
Audit	-	-	7,100	0%
Assessment roll preparation	444	1,333	5,332	25%
Arbitrage rebate calculation	-	-	1,250	0%
Dissemination agent	88	263	1,051	25%
Trustee	-	-	6,500	0%
ADA website compliance	-	-	210	0%
Website and E-blast communications	-	-	1,220	0%
Postage	21	42	2,000	2%
Legal advertising	-	-	1,225	0%
Office supplies	367	367	300	122%
Other current charges	153	510	1,500	34%
Annual special district fee	-	175	175	100%
Insurance	-	7,939	8,500	93%
Property taxes	-	-	178	0%
Total administrative expenses	<u>5,237</u>	<u>22,922</u>	<u>116,655</u>	20%
Field Operations				
Landscape maintenance	3,525	32,079	96,313	33%
Landscape replacement	-	-	10,000	0%
Tree maintenance	-	2,650	10,000	27%
Lake Plant Maintenance	-	-	27,150	0%
Playground maintenance	-	-	1,500	0%
Clubhouse irrigation	-	-	3,000	0%
Pump maintenance/repair	-	-	4,500	0%
Electrical repairs	-	441	1,000	44%
Lake maintenance	1,519	5,872	26,681	22%
Lake bank degradation	-	-	106,657	N/A
Aeration maintenance	-	-	9,000	0%
Aeration utilities	-	-	12,000	0%
Contingency	-	-	5,000	0%
Holiday decorations	-	8,175	8,175	100%
Animal control	135	405	1,500	27%
Operating supplies	209	492	-	N/A
Total field operations	<u>5,388</u>	<u>50,114</u>	<u>322,476</u>	16%

**STONEGATE
COMMUNITY DEVELOPMENT DISTRICT
STATEMENT OF REVENUES, EXPENDITURES,
AND CHANGES IN FUND BALANCES
GENERAL FUND
FOR THE PERIOD ENDED DECEMBER 31, 2023**

	Current Month	Year to Date	Budget	% of Budget
Clubhouse				
Telephone	-	-	3,480	0%
Utilities	552	10,738	63,000	17%
Insurance	-	22,702	28,901	79%
Flood insurance	-	-	4,037	0%
Alarm monitoring	64	191	720	27%
Fire monitoring	-	135	540	25%
Pool maintenance	2,300	6,900	15,000	46%
Pool health inspections	-	-	750	0%
Air conditioning R&M	2,000	5,425	1,000	543%
Clubhouse operation and management				
Clubhouse management	20,872	62,617	250,467	25%
Special events	5,549	25,884	35,000	74%
Gym maintenance	-	-	1,500	0%
Gym equipment lease	-	-	8,400	0%
Pool attendant	-	-	7,906	N/A
Office supplies	3	3	4,000	0%
Repairs and maintenance	954	1,520	15,000	10%
New access yearly fee	-	-	2,000	0%
Wall paint and repairs	-	498	10,000	5%
Pool system upgrade	-	-	275,000	0%
Pool permit inspection & repair	4,500	4,500	-	N/A
Pressure cleaning	-	57	1,000	6%
Janitorial supplies	250	296	15,700	2%
Stormdrain cleanout	-	-	7,000	0%
Contingencies	-	-	9,000	0%
Total clubhouse	<u>37,044</u>	<u>141,466</u>	<u>759,401</u>	19%
Infrastructure reinvestment				
Capital outlay				
General	-	-	15,000	0%
Total clubhouse reserves	<u>-</u>	<u>-</u>	<u>15,000</u>	0%
Other fees and charges				
Property appraiser & tax collector	7,144	9,486	14,374	66%
Total other fees and charges	<u>7,144</u>	<u>9,486</u>	<u>14,374</u>	66%
Total expenditures	<u>54,813</u>	<u>223,988</u>	<u>1,227,906</u>	18%
Net increase/(decrease) of fund balance	660,900	732,327	160,000	
Fund balances - beginning	1,057,924	986,497	972,840	
Fund balances - ending				
Committed				
Clubhouse renewal & replacement	155,000	155,000	155,000	
Assigned				
3 months working capital	303,227	303,227	303,227	
Disaster	225,000	225,000	225,000	
Unassigned	1,035,597	1,035,597	449,613	
Fund balance - ending	<u>\$ 1,718,824</u>	<u>\$ 1,718,824</u>	<u>\$ 1,132,840</u>	

**STONEGATE
COMMUNITY DEVELOPMENT DISTRICT
STATEMENT OF REVENUES, EXPENDITURES,
AND CHANGES IN FUND BALANCES
DEBT SERVICE FUND: SERIES 2013 (REFUNDED SERIES 2004)
FOR THE PERIOD ENDED DECEMBER 31, 2023**

	Current Month	Year To Date	Budget	% of Budget
REVENUES				
Assessments	\$ 311,107	\$ 413,094	\$ 600,910	69%
Interest	251	1,785	-	N/A
Total revenues	<u>311,358</u>	<u>414,879</u>	<u>600,910</u>	69%
EXPENDITURES				
Debt service				
Principal	-	-	350,000	0%
Interest 11/1	-	122,325	122,325	100%
Interest 5/1	-	-	122,325	0%
Property appraiser & tax collector	3,111	4,131	6,260	66%
Total expenditures	<u>3,111</u>	<u>126,456</u>	<u>600,910</u>	21%
Net increase/(decrease) of fund balance	308,247	288,423	-	
Fund balances - beginning	159,425	179,249	160,429	
Fund balances - ending	<u>\$ 467,672</u>	<u>\$ 467,672</u>	<u>\$ 160,429</u>	

**STONEGATE
COMMUNITY DEVELOPMENT DISTRICT
STATEMENT OF REVENUES, EXPENDITURES,
AND CHANGES IN FUND BALANCES
DEBT SERVICE FUND: SERIES 2020
FOR THE PERIOD ENDED DECEMBER 31, 2023**

	Current Month	Year To Date	Budget	% of Budget
REVENUES				
Assessments	\$ 166,895	\$ 221,606	\$ 322,360	69%
Interest	1,333	4,546	-	N/A
Total revenues	<u>168,228</u>	<u>226,152</u>	<u>322,360</u>	70%
EXPENDITURES				
Debt service				
Principal	-	5,000	195,000	3%
Interest 11/1	-	60,225	60,225	100%
Interest 5/1	-	-	60,225	0%
Property appraiser & tax collector	1,669	2,216	3,358	66%
Total debt service	<u>1,669</u>	<u>67,441</u>	<u>318,808</u>	21%
Net increase/(decrease) of fund balance	166,559	158,711	3,552	
Fund balances - beginning	380,318	388,166	370,040	
Fund balances - ending	<u>\$ 546,877</u>	<u>\$ 546,877</u>	<u>\$ 373,592</u>	

**STONEGATE
COMMUNITY DEVELOPMENT DISTRICT
STATEMENT OF REVENUES, EXPENDITURES,
AND CHANGES IN FUND BALANCES
CAPITAL PROJECTS FUND: SERIES 2020
FOR THE PERIOD ENDED DECEMBER 31, 2023**

	<u>Current Month</u>	<u>Year To Date</u>
REVENUES		
Interest	\$ 1,408	\$ 4,367
Total revenues	<u>1,408</u>	<u>4,367</u>
EXPENDITURES		
Capital outlay	<u>1,979</u>	<u>26,433</u>
Total expenditures	<u>1,979</u>	<u>26,433</u>
Excess/(deficiency) of revenues over/(under) expenditures	(571)	(22,066)
Fund balances - beginning	334,399	355,894
Fund balances - ending	<u>\$ 333,828</u>	<u>\$ 333,828</u>

**STONEGATE
COMMUNITY DEVELOPMENT DISTRICT
CHECK REGISTER
DECEMBER 31, 2023**

Stonegate CDD Check Detail December 2023

Type	Num	Date	Name	Item	Account	Paid Amount	Original Amount
Bill Pmt -Check	CBI	12/07/2023	COMCAST CORPORATION		101.000 · Bank of America - Checking		-551.67
Bill	07601...	12/06/2023		536.010 · Utilities		-551.67	551.67
TOTAL						-551.67	551.67
Bill Pmt -Check	CBI	12/15/2023	IMAGENET CONSULTING		101.000 · Bank of America - Checking		-137.79
Bill	81583...	12/13/2023		537.200 · Operating Supplies		-137.79	137.79
TOTAL						-137.79	137.79
Bill Pmt -Check	CBI	12/15/2023	FEDEX		101.000 · Bank of America - Checking		-20.90
Bill	8-345-...	12/13/2023		519.410 · Postage		-20.90	20.90
TOTAL						-20.90	20.90
Bill Pmt -Check	14472	12/07/2023	AL-FLEX EXTERMINATORS, INC.		101.000 · Bank of America - Checking		-135.00
Bill	4496	12/06/2023		537.500 · Animal Control		-135.00	135.00
TOTAL						-135.00	135.00
Bill Pmt -Check	14473	12/07/2023	ALLSTATE RESOURCE MANAGEMENT, I...		101.000 · Bank of America - Checking		-1,519.00
Bill	4071	12/06/2023		537.003 · Lake Maintenance		-1,519.00	1,519.00
TOTAL						-1,519.00	1,519.00
Bill Pmt -Check	14474	12/07/2023	ARMANDO GARCIA LAND SERVICE INC		101.000 · Bank of America - Checking		-2,675.00
Bill	763367	12/06/2023		537.470 · Tract C		-2,675.00	2,675.00
TOTAL						-2,675.00	2,675.00
Bill Pmt -Check	14475	12/07/2023	GONZALEZ CANO AC SERVICES		101.000 · Bank of America - Checking		-2,000.00
Bill	20	12/06/2023		536.020 · Air Conditioning R&M		-2,000.00	2,000.00
TOTAL						-2,000.00	2,000.00
Bill Pmt -Check	14476	12/07/2023	M&M POOL & SPA SERVICES, CORP		101.000 · Bank of America - Checking		-2,300.00
Bill	5000	12/06/2023		536.004 · Pool Maintenance		-2,300.00	2,300.00
TOTAL						-2,300.00	2,300.00
Check	14477	12/07/2023	STONEGATE CDD		101.000 · Bank of America - Checking		-100,966.97

Stonegate CDD
Check Detail
 December 2023

Type	Num	Date	Name	Item	Account	Paid Amount	Original Amount
					207.203 · Due to DSF Series 2013	-100,966.97	100,966.97
TOTAL						-100,966.97	100,966.97
Check	14478	12/07/2023	STONEGATE CDD		101.000 · Bank of America - Checking		-54,164.18
					207.204 · Due to DSF series 2020	-54,164.18	54,164.18
TOTAL						-54,164.18	54,164.18
Bill Pmt -Check	14479	12/15/2023	WRATHELL, HUNT & ASSOCIATES, LLC		101.000 · Bank of America - Checking		-4,169.83
Bill	2023-1...	12/13/2023			512.311 · Management Fees	-3,637.92	3,637.92
					513.310 · Assessment Roll Preparation	-444.33	444.33
					513.315 · Dissemination Fees	-87.58	87.58
TOTAL						-4,169.83	4,169.83

**STONEGATE
COMMUNITY DEVELOPMENT DISTRICT
INVOICES
DECEMBER 31, 2023**

AL-FLEX EXTERMINATORS, INC.
 4035 SW 98th Ave
 Miami, FL 33165
 +1 3055520141
 pc@al-flex.com
<https://www.alflexexterminators.com/>

Invoice

537.500



BILL TO

MALIBU BAY CLUBHOUSE
 C/O STONEGATE CDD
 1020 MALIBU WAY
 HOMESTEAD, FL 33033 US

SHIP TO

MALIBU BAY CLUBHOUSE
 C/O STONEGATE CDD
 1020 MALIBU WAY
 HOMESTEAD, FL 33033 US

INVOICE #	DATE	TOTAL DUE	DUE DATE	TERMS	ENCLOSED
4496	12/01/2023	\$135.00	12/31/2023	Net 30	

DATE	ACTIVITY	DESCRIPTION	QTY	RATE	AMOUNT
	PEST CONTROL	MONTHLY PEST CONTROL SERVICES @ 1020 MALIBU WAY	1	135.00	135.00

SUBTOTAL	135.00
TAX	0.00
TOTAL	135.00
BALANCE DUE	\$135.00



Invoice

4071

Stonegate CDD
 c/o Wrathell Hunt and Associates, LLC
 2300 Glades Road Suite 410W
 Boca Raton, FL 33431

Contact Us
 Phone: (954) 382-9766
 jweinsier@allstatemanagement.com

Due Date 12/31/2023
 Terms Net 30 **537.003**
 Account # 3782 **001**
 PO #

Service Month:
12/1/2023

Description	Amount Due
Lake and Canal Management Services Recurring	1,300.00
Aquascaping Maintenance Services Recurring	219.00
<div style="border: 1px solid black; background-color: #cccccc; padding: 5px; display: inline-block;">There will be a \$25 charge for all returned checks.</div>	
Total	\$1,519.00

Stonegate CDD
 c/o Wrathell Hunt and Associates, LLC
 2300 Glades Road Suite 410W
 Boca Raton, FL 33431

Invoice # 4071
 Account # 3782

ALLSTATE RESOURCE MANAGEMENT, INC.
 6900 SW 21st Court, Unit #9
 Davie, Florida 33317

Amount Enclosed: \$ _____

Please return this portion with your payment

INVOICE

**Armando Garcia Land Service
INC**
16650 SW 203 AVE
Miami, FL 33187

armando-garcia-
landservice@hotmail.com
(786) 298-7104

Stonegate CDD

Bill to

Stonegate CDD
2300 Glades Rd. Ste. 410 W
Boca Raton, FL 33431

Invoice details

Invoice no.: 763367

Invoice date: 12/04/2023

Due date: 01/03/2024

537.470
001

#	Date	Product or service	SKU	Qty	Rate	Amount
1.	12/01/2023	Cut the Grass Cut the Grass 12/1. & 12/15 #537.400		2	\$950.00	\$1,900.00
2.	12/15/2023	Cut the Grass Tract C. Maintenance #537.470		2	\$200.00	\$400.00
3.	12/01/2023	Irrigation System Second payment of Maintenance of the Irrigation System/ Fiscal Year 2024 #537.450			\$375.00	\$375.00

Total

\$2,675.00

Note to customer

#537.400
#537.470
#537.450

Hello Stonegate Comm Dev Dist,

Thanks for choosing Comcast Business.

Your bill at a glance

For 1020 MALIBU WAY, HOMESTEAD, FL, 33033-5350

Previous balance		\$1,112.83
One-time EFT Payment - thank you Nov 02		-\$1,112.83
Balance forward		\$0.00
Regular monthly charges	Page 3	\$547.65
Taxes, fees and other charges	Page 3	\$4.02
New charges		\$551.67

Amount due Dec 13, 2023 \$551.67

Need help?

Visit business.comcast.com/help or see page 2 for other ways to contact us.

Your bill explained

- Any payments received or account activity after Nov 22, 2023 will show up on your next bill. View your most up-to-date account balance at business.comcast.com/myaccount.
- This page gives you a quick summary of your monthly bill. A detailed breakdown of your charges begins on page 3.



536.010
001

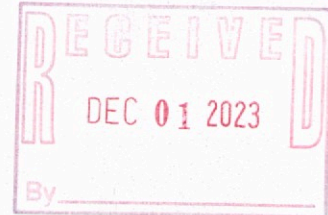

Detach the bottom portion of this bill and enclose with your payment

Please write your account number on your check or money order

Do not include correspondence with payment

COMCAST
BUSINESS

1100 NORTHPOINT PKWY W PALM
BCH FL 33407-1937
96330350 NO RP 22 20231122 NNNNNNNY 0001503 0008

STONEGATE COMM DEV DIST
ATTN ACCOUNTS PAYABLE
2300 GLADES RD STE 410W
BOCA RATON, FL 33431-8556

Account number

8495 60 060 0760104

Payment due

Dec 13, 2023

Please pay

\$551.67

Amount enclosed

\$

Make checks payable to Comcast
Do not send cash



Send payment to

COMCAST
PO BOX 71211
CHARLOTTE NC 28272-1211



849560060076010400551671

Download the Comcast Business App

Business is always moving. Our app was built for this. Manage your account anytime, anywhere with the Comcast Business App – the easy way to manage your services on the go.

- Manage your account details
- Pay your bill and customize billing options
- View upcoming appointments

Scan the QR Code with your phone or mobile device to get started.



Faster speeds. More solutions. Bigger savings.

Comcast Business now offers **NEW** packages with faster speeds and innovative Voice and security solutions – at a better value.

Call today for a **FREE** account review at **877-564-0318**.



Need help? We're here for you



Visit us online

Get help and support at **business.comcast.com/help**



Call us anytime

800-391-3000
Open 24 hours, 7 days a week for billing and technical support

Useful information

Moving?

We can help ensure it's a smooth transition. Visit **business.comcast.com/learn/moving** to learn more.

Accessibility:

If you are hearing impaired, call 711. For issues affecting customers with disabilities, call **1-855-270-0379**, chat live at **support.xfinity.com/accessibility**, email **accessibility@comcast.com**, fax **1-866-599-4268** or write to Comcast at 1701 JFK Blvd., Philadelphia, PA 19103-2838
Attn: M. Gifford.



Ways to pay



No more mailing monthly checks

Set up Auto Pay to save time, energy and stamps. It's easy to enroll, just visit **business.comcast.com/myaccount**



Go paperless and say goodbye to clutter

Sign up for Paperless Billing to view and pay your bill online. It's faster, easier and helps cut down on clutter. Visit **business.comcast.com/myaccount** to get started.

Additional billing information

More ways to pay:



Online

Visit My Account at **business.comcast.com/myaccount**



Comcast Business App

Download the Comcast Business App



In-Store

Visit **business.comcast.com/servicecenter** to find a store near you



Regular monthly charges		\$547.65
Comcast Business		\$439.85
Packaged services		\$493.95
Connection Pro	\$39.95	
Data, Voice, Access Package, Includes: Business Internet Gigabit Extra, 1 Mobility Voice Line, SecurityEdge, and WiFi Pro Expanded Coverage.	\$429.00	
Mobility Voice Line Business Voice.	\$44.95	
Voice Credit	-\$19.95	
Discounts		-\$189.00
Bundle Discount	-\$189.00	
Comcast Business services		\$134.90
TV Preferred Business Video.	\$99.95	
Sports and Entertainment Package.	\$34.95	

Equipment & services		\$59.80
TV Box + Remote	\$9.95	
Service To Additional TV With TV Box and Remote. Qty 2 @ \$9.95 each	\$19.90	
Equipment Fee Voice and WiFi Pro Expanded Coverage.	\$29.95	

Service fees		\$48.00
Directory Listing Management Fee	\$5.00	
Voice Network Investment	\$5.00	
Broadcast TV Fee	\$21.55	
Regional Sports Fee	\$16.45	

Taxes, fees and other charges		\$4.02
Other charges		\$4.02
Regulatory Cost Recovery	\$2.02	
Federal Universal Service Fund	\$2.00	

What's included?



Internet: Fast, reliable internet on our Gig-speed network



TV: Keep your employees informed and customers entertained



Voice Numbers: (305)247-4094, (305)247-8859

Visit business.comcast.com/myaccount for more details

You've saved \$208.95 this month with your voice credit and bundle discounts.



Additional information

Account Number
8495 60 060 0760104

Billing Date
Nov 22, 2023

Services From
Dec 02, 2023 to Jan 01, 2024

Page
4 of 6

Price Change Notice: As content programmers charge more to carry their networks, our costs continue to rise. Effective December 18, 2023, your Regional Sports Fee will increase to \$16.50 per month, and your Broadcast TV fee will increase to \$24.40 per month. To learn more about Comcast Business fees, please visit business.comcast.com/understand-your-bill or call us at 800-391-3000.

The Regulatory Cost Recovery fee is neither government mandated nor a tax, but is assessed by Comcast to recover certain federal, state, and local regulatory costs.

TV Update: Effective December 31, 2023, DW Deutsch + is ceasing operations and will no longer be available with Comcast Business. The channel will be removed from your bill.

TV Update: Effective December 28, 2023, Z Living will no longer be available with Comcast Business.

Recent and Upcoming Programming Changes: Information on recent and upcoming programming changes can be found at xfinity.com/programmingchanges/ or by calling 866-216-8634.



**COMCAST
BUSINESS**

**Important information regarding
Comcast Business services and pricing
Effective December 18, 2023**

Dear Comcast Business Customer:

At Comcast Business, we are proud of our investments in our network, technology, and people to provide services to help keep your business prepared for what's next. As we continue to make these investments to bring you exceptional performance and reliability, we continue to make efforts to control costs in this challenging economic environment. Even so, our costs have increased for programming, technology, and service improvements. From time to time, we must pass along cost increases to our customers.

We are writing to inform you of upcoming price increases. The following changes will occur on December 18, 2023. Prices do not include applicable taxes and other fees.

Comcast Business Video

Service	Current Monthly Service Charge:		New Monthly Service Charge Effective 12/18/2023:
Video Basic	\$42.95	>	\$50.95
Video Select	\$47.95	>	\$57.95
Video Variety	\$64.95	>	\$74.95
Video Standard	\$89.95	>	\$99.95
Video Preferred	\$114.95	>	\$124.95

Comcast Business Voice

Service	Current Monthly Service Charge:		New Monthly Service Charge Effective 12/18/2023:
Full Feature 4+ Line	29.45	>	\$34.45*
Directory Listing Management Fee (DLM)	\$5.00	>	\$6.00
Voice Network Investment Fee	\$5.00	>	\$6.00

*Charges apply per line, after 3 lines

Comcast Business Internet

Service	Current Monthly Service Charge:		New Monthly Service Charge Effective 12/18/2023:
Basic Connect	Charges Vary	>	Charges Vary
Standard Connect	Charges Vary	>	Charges Vary
Deluxe 25	\$101.95	>	\$106.95
Internet Premium	\$111.95	>	\$116.95
Business Internet 75	\$152.95	>	\$157.95
Business Internet 150	\$254.95	>	\$259.95
Business Internet 300	\$354.95	>	\$359.95

Comcast Business Equipment

Service	Current Monthly Equipment Charge:		New Monthly Equipment Charge Effective 12/18/2023:
Internet and/or Voice	\$19.95	>	\$22.95



Account Number
8495 60 060 0760104

Billing Date
Nov 22, 2023

Services From
Dec 02, 2023 to Jan 01, 2024

Page
6 of 6

To learn more about Comcast Business fees, please visit business.comcast.com/understand-your-bill or call us at 800-391-3000.

Thank you for being a valued Comcast Business customer.

Sincerely,
Comcast Business





GONZALEZ CANO AC SERVICES

536.020

Invoice

Invoice No: 20 Date: 12/03/2023 Terms: NET 0 Due Date: 12/03/2023	8842 SW 215th Ln Miami, FL, 33189 (786) 532-6870
Bill To: Stonegate CDD/ Malibu Bay manager@unusmgmt.com 1020 Malibu Way Homestead, FL, 33033-5350 305-247-8859	

Description	Quantity	Rate	Amount
Service: -Replace Condenser Coil -Fix 5 leaks	1	\$2,000.00	\$2,000.00
		Subtotal	\$2,000.00
		Total	\$2,000.00
		Paid	\$0.00
		BALANCE DUE	\$2,000.00

- Invoice 20 - 12/03/2023

Please detach and send with remittance to:

Gonzalez Cano AC Services
8842 SW 215th Ln Miami, FL, 33189

Remittance Advice for Invoice # 20 on 12/03/2023

Balance Due \$2,000.00

Paid _____

Received From: Stonegate CDD/ Malibu Bay

Card Type			
Cardholder's Name	_____		
Card Number	<input type="text"/> <input type="text"/> <input type="text"/> <input type="text"/> <input type="text"/> <input type="text"/> <input type="text"/> <input type="text"/> <input type="text"/> <input type="text"/> <input type="text"/> <input type="text"/> <input type="text"/> <input type="text"/> <input type="text"/> <input type="text"/> <input type="text"/> <input type="text"/> <input type="text"/> <input type="text"/> <input type="text"/> <input type="text"/> <input type="text"/>	CVV	<input type="text"/> <input type="text"/> <input type="text"/>
Expiry Date	<input type="text"/> <input type="text"/> / <input type="text"/> <input type="text"/>		
Signature	<input type="text"/>		

M&M POOL & SPA SERVICES, CORP.

14304 145th Pl
Miami, FL 33186 US
+1 7869728875
mmpoolspaservicescorp@gmail.com
www.mmpoolspaservicescorp.com



M&M POOL & SPA SERVICES
Cleaning & Maintenance

536.004

INVOICE

BILL TO
STONEGATE CDD / MALIBU BAY CLUB HOUSE
1020 MALIBU WAY
HOMESTAD, FL 33033 US

SHIP TO
STONEGATE CDD / MALIBU BAY CLUB HOUSE
1020 MALIBU WAY
HOMESTAD, FL 33033 US

INVOICE 5000
DATE 11/29/2023
TERMS NET 5
DUE DATE 12/04/2023

DATE	DESCRIPTION	QTY	RATE	AMOUNT
11/29/2023	December Pool Services	1	2,300.00	2,300.00

Thank you for your business! I take credit cards, ACH payments, Zelle can be sent to 7869728875, Venmo can be sent to @Marcelo-Valdes, and check can be sent to 14304 SW 145 PL, Miami, FL 33186.

SUBTOTAL	2,300.00
TAX	0.00
TOTAL	2,300.00
BALANCE DUE	\$2,300.00



Invoice Number 8-345-40350	Invoice Date Dec 12, 2023	Account Number 5297-2710-0	Page 1 of 2
--------------------------------------	-------------------------------------	--------------------------------------	----------------

FedEx Tax ID: 71-0427007

Billing Address:

STONE GATE CDD
2300 GLADES RD STE 410W
BOCA RATON FL 33431-8556

Shipping Address:

STONE GATE CDD
2300 GLADES RD STE 410W
BOCA RATON FL 33431-8556

**Invoice Questions?
Contact FedEx Revenue Services**

Phone: 800.645.9424
M-F 7-5 (CST)
Internet: fedex.com/usgovt

Invoice Summary

FedEx Express Services

Total Charges USD \$20.90
TOTAL THIS INVOICE USD \$20.90

519.410
001

Other discounts may apply.

To pay your FedEx invoice, please go to www.fedex.com/payment. Thank you for using FedEx.



Detailed descriptions of surcharges can be located at fedex.com

To ensure proper credit, please return this portion with your payment to FedEx. Please do not staple or fold. Please make check payable to FedEx.

Invoice Number 8-345-40350	Invoice Amount USD \$20.90	Account Number 5297-2710-0
--------------------------------------	--------------------------------------	--------------------------------------

Remittance Advice

Your payment is due by Jan 26, 2024

8345403508000002090952972710080000000000000000209090



STONE GATE CDD
2300 GLADES RD STE 410W
BOCA RATON FL 33431-8556

FedEx
P.O. Box 371461
Pittsburgh PA 15250-7461



Invoice Number 8-345-40350	Invoice Date Dec 12, 2023	Account Number 5297-2710-0	Page 2 of 2
--------------------------------------	-------------------------------------	--------------------------------------	----------------

FedEx Express Shipment Detail By Payor Type (Original)

Ship Date: Dec 07, 2023	Cust. Ref.: STONEGATE DSF	Ref.#2:
Payor: Third Party	Ref.#3:	

Fuel Surcharge - FedEx has applied a fuel surcharge of 16.25% to this shipment.
Distance Based Pricing, Zone 7

Automation	INET	Sender	Recipient
Tracking ID	774388135998	Archana Gujja	Mary Dallatore
Service Type	FedEx Standard Overnight	Wrathell, Hunt & Associates, L	Wells Fargo Bank-CTS payment p
Package Type	FedEx Envelope	2300 Glades Road	1801 Parkview Drive, 1st Floor
Zone	07	BOCA RATON FL 33431 US	SAINT PAUL MN 55126 US
Packages	1		
Rated Weight	N/A		
Delivered	Dec 08, 2023 09:21		
Svc Area	A1	Transportation Charge	9.77
Signed by	S.IBE	Fuel Surcharge	0.68
FedEx Use	000000000/61306/_	Total Charge	USD \$10.45

Ship Date: Dec 07, 2023	Cust. Ref.: STONEGATE DSF	Ref.#2:
Payor: Third Party	Ref.#3:	

Fuel Surcharge - FedEx has applied a fuel surcharge of 16.25% to this shipment.
Distance Based Pricing, Zone 7

Automation	INET	Sender	Recipient
Tracking ID	787621154260	Archana Gujja	Lockbox Services-12-2657
Service Type	FedEx Standard Overnight	Wrathell, Hunt & Associates, L	US Bank, NA CDD
Package Type	FedEx Envelope	2300 Glades Road	EP-MN-01LB
Zone	07	BOCA RATON FL 33431 US	SAINT PAUL MN 55108 US
Packages	1		
Rated Weight	N/A		
Delivered	Dec 08, 2023 10:44		
Svc Area	A1	Transportation Charge	9.77
Signed by	S.WHITE	Fuel Surcharge	0.68
FedEx Use	000000000/61306/_	Total Charge	USD \$10.45

Third Party Subtotal	USD	\$20.90
Total FedEx Express	USD	\$20.90

FedEx® Billing Online

FedEx Billing Online allows you to efficiently manage and pay your FedEx invoices online. It's free, easy and secure. FedEx Billing Online helps you streamline your billing process. With all your FedEx shipping information available in one secure online location, you never have to worry about misplacing a paper invoice or sifting through reams of paper to find information for past shipments. Go to fedex.com to sign up today!

Wrathell, Hunt & Associates, LLC

2300 Glades Rd.
Suite 410W
Boca Raton, FL 33431

Invoice

Date	Invoice #
12/1/2023	2023-1974

Bill To:
Stonegate CDD PO Box 810036 Boca Raton, FL 33481

Description	Amount
Management 512.311	3,637.92
Assessment Services 513.310	444.33
Dissemination Agent 513.315 001	87.58
<i>Building client relationships one step at a time ...</i>	Total \$4,169.83

IMAGENET CONSULTING, LLC
 PO BOX 41602
 PHILADELPHIA, PA 19101-1602

REMITTANCE SECTION

Invoice Number: 81583269
 Due Date: 01/01/2024
 Due This Period: \$137.79

Amount Enclosed: \$ _____

537.200
 001

Please make check payable to:

IMAGENET CONSULTING, LLC
 PO BOX 41602
 PHILADELPHIA, PA 19101-1602



STONEGATE CDD
 ATTN: AP
 2300 GLADES RD STE 410W
 BOCA RATON FL 33431-8556

2100000815832690000137791

Detach here. Please include the top payment coupon with your payment. Please allow 5-7 days for U.S. Postal Service delivery.

IMAGENET CONSULTING, LLC
 PO BOX 41602
 PHILADELPHIA, PA 19101-1602

Contract Number: 500-50396510
 Invoice Number: 81583269
 Account Number: 1626036
 Site Number: 5608077
 Invoice Date: 12/09/2023

WWW.LEASEDIRECT.COM

Period of Performance: 12/01/2023-12/31/2023
Due This Period: \$137.79

IMPORTANT MESSAGES

MAKING ELECTRONIC PAYMENTS?

*Please review your equipment location(s) for tax purposes.

- ✓ If paying by ACH or Wire, please forward detailed remittance advice to EFT@LEASEDIRECT.COM to ensure timely application of payment.
- ✓ Enroll in direct debit by visiting WWW.LEASEDIRECT.COM and clicking on manage payments

See Reverse For Important Information

INVOICE DETAILS

Description	Payment Amount	Tax	Total Amount	Applied Amount	Remaining Amount Due
PAYMENT	\$110.00	\$7.70	\$117.70	\$0.00	\$117.70
INSURANCE	\$18.77	\$1.32	\$20.09	\$0.00	\$20.09
Billed this Invoice	\$128.77	\$9.02	\$137.79	\$0.00	\$137.79

(See account summary for details of any past due balances.)

ASSET DETAILS

Contract Number	Serial Number	Purchase Order	Make / Model	Asset Number	Install Date	Cost Center	Department	Payment Amount	Tax	Total Amount
500-50396510	MXBCQ3H00R		HP / PageWide Man Color P77650dns	50396510_1				\$110.00	\$7.70	\$117.70

Asset Location: 1020 NE 34TH AVE HOMESTEAD MIAMI-DADE FL 33033 United States

Asset Amount Total: \$117.70

Contact Us

Privacy Notice: We're updating our Privacy Statement to reflect our privacy practices and to comply with new laws and regulations which take effect in 2023. Those changes include updates to your privacy rights and options. This is part of our ongoing commitment to be transparent about the types of personal information we collect, where that information comes from, how we use it, and with whom we disclose it. The new updates will take effect on December 31, 2022, and no further action is required by you. You can learn more about our privacy practices at our website (<https://www.leasedirect.com/usprivacy>).

WWW.LEASEDIRECT.COM

- ✓ View contract and invoice copies
- ✓ View open balances and a Pay History of your contract
- ✓ Update your insurance
- ✓ Update your Billing or Asset Address
- ✓ Enroll in Paperless
- ✓ Enroll in Direct Debit

Correspondence Address

IMAGENET CONSULTING, LLC
1111 OLD EAGLE SCHOOL RD
WAYNE, PA 19087-1453
*Please provide your contract number

Customer Service

800-736-0220

Important Reminder

Enclose remittance slip with your check and send it to the address on the reverse side to ensure accurate and timely processing of your payment. **Please remit payments at least 5 days prior to due date. Please record your Invoice number on the check.**

Explanation of Charges

It is important to us that you understand the charges on your invoice. Please refer to this guide for assistance.

1. **DOCUMENTATION/ORIGINATION FEE** – A one-time fee assessed on new transactions to cover our expenses for preparing financing statements and other documentation costs.
2. **INTERIM PAYMENT** – A charge to account for the partial month, prior to the first full billing cycle, calculated per the terms and conditions in the contract.
3. **INSURANCE CHARGE** – A charge due each billing period as the result of the equipment being insured by the lessor against theft or damage.
4. **PAYMENT** – Amount due each billing period in accordance with the terms of the contract.
5. **LATE FEE** – Assessed when a payment is not received by its due date, as provided by the contract.
6. **FINANCE CHARGE** – Assessed when a payment is not received and is over thirty (30) days past its due date.
7. **PROPERTY TAX** – The lessor, as the owner of the equipment, is assessed and pays property tax to the appropriate taxing authority on an annual basis. Per the contract, the Lessee has agreed to reimburse the Lessor for all property taxes paid on their behalf plus reasonable administrative costs. For questions about taxes, call the Customer Service number above.
8. **RETURNED CHECK FEE** – Assessed each time a check is returned for any reason.
9. **CUSTOMER SERVICE FEE** – Assessed when a request for an amortization schedule, an invoice copy, a pay history or additional contract copy is requested.
10. **ACCOUNT SUMMARY** – Overview of prior billed invoices for which a partial or no payment was received at the time the current invoice was printed.
11. **TAX OR LESSOR SURCHARGE** – Taxes due in accordance with the tax laws of the state(s) where the equipment is located. For tax related questions, call the Customer Service number above.
12. **PURCHASE ORDER** – Reference to purchase order number is for equipment identification purposes only.

8935 NW 35 Lane, Suite 101
 Doral, FL 33172
 Phone (305) 640-1345
 E-mail silvia.alvarez@alvarezeng.com



Invoice

Date	Invoice No.
12/8/2023	7536

Bill To
Stonegate CDD Wrathell, Hunt & Associates, LLC 2300 Glades Road Suite 410W Boca Raton, FL 33431

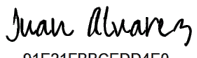
DocuSigned by:

 91E21FBBCEDD4E0...

Project Number / Name: 080903-3 Stonegate Operations

Juan R. Alvarez, P.E.

Invoice Period: 11/1/23-12/1/23

Description	Qty (hrs)	Rate (\$ / hr)	Amount (\$)
11/15/2023 Senior Admin Asst Prepare requisition 37	0.50	95.00	47.50
11/16/2023 Senior Admin Asst Review and file Allstate reports	0.25	95.00	23.75
11/27/2023 Principal Preparation for the next CDD meeting. Telephone conversation with District Manager.	0.25	220.00	55.00
519.320			
001			
Amount due this Invoice			\$126.25

Wiring Instructions:

Name: Alvarez Engineers, Inc.
 Bank: Bank of America
 Account No. 1596250258
 ABA No. 0260-0959-3

BILLING, COCHRAN, LYLES, MAURO & RAMSEY, P.A.
LAS OLAS SQUARE, SUITE 600
515 EAST LAS OLAS BOULEVARD
FORT LAUDERDALE, FLORIDA 33301
(954) 764-7150

STONEGATE COMMUNITY DEVELOPMENT DISTRICT
WRATHELL, HUNT & ASSOCIATES, LLC
P.O. BOX 810036
BOCA RATON FL 33481

Page: 1
11/30/2023
Account No: 526-030290
Statement No: 184518

Attn: CRAIG WRATHELL

STONEGATE CDD

514.310
001

Fees

Monthly minimum billing for general/routine legal services provided for in CDD Engagement Letter, including, but not limited to:
Communications with District Manager and District Staff re: routine operations of the CDD;
Communications with State and local government agencies re: CDD matters, requests for information, audits, etc.; Update and maintain CDD records, notices, filings, etc.; Review miscellaneous correspondence re: CDD; Scheduling matters involving the CDD and Agendas re: Meetings of Board of Supervisors; Monitoring litigation matters, receiving and processing all notices, service of process, etc., as Registered Agent of the CDD; Reviewing and reporting upon changes in legislation and regulatory measures affecting the CDD

For Current Services Rendered	400.00
Previous Balance	\$852.50
Total Current Work	400.00

Payments

11/15/2023	PAYMENT RECEIVED - THANK YOU	-852.50
	Balance Due	<u>\$400.00</u>

PLEASE MAKE CHECKS PAYABLE TO
BILLING, COCHRAN, LYLES, MAURO & RAMSEY, P.A.
PLEASE RETURN ONE COPY OF THIS STATEMENT WITH YOUR PAYMENT
IRS NO. 59-1756046



FRED SEARL
334 EAST LAKE ROAD #214
PALM HARBOR FL 34685

INVOICE

BILL TO
ATTN: C / O WRATHELL, HUNT & ASSOC
STONEGATE CDD
STE 410W
2300 GLADES RD
BOCA RATON FL 33431-8556

000048



SHIP TO
ATTN: C/O WRATHELL, HUNT & ASSOC
STONEGATE CDD
2300 GLADES RD STE 410W
BOCA RATON FL 33431-8556

ISSUANCE DATE 12/6/2023
DUE DATE 1/4/2024
CUSTOMER ID 600104074
INVOICE NUMBER 9003268944
PO NUMBER LING CHEN



Advisor No: 00V9-09 Cust No: PYM2KF Order No: CDP681

PRODUCT NUMBER	SHIP DATE	DESCRIPTION	RATE	VOLUME	UOM	DISCOUNT	AMOUNT
SFSL1B1	12/04/2023	LASER L1 CHECK 1PT PBLUE LINEN-3774 Order#:CDP681	0.70004	250	EA	0.00	175.01
EZSPREM	12/04/2023	EZSHIELD PREMIUM SERVICE Order#:CDP681	0.00000	250	EA	0.00	0.00
SGCE2373	12/04/2023	ENVELOPE DBL WIN SELF BLANK Order#:CDP681	0.29016	500	EA	0.00	145.08

PRODUCTS & SERVICES SUBTOTAL		320.09
ORDER DISCOUNTS		0.00
SHIPPING & PROCESSING		46.82
TAX		0.00
INVOICE AMOUNT		366.91
PAYMENTS & ADJUSTMENTS		0.00
AMOUNT DUE (USD)		\$ 366.91

519.510
001

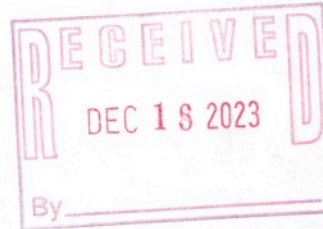

Pay online at gosafeguardpayment.com to authorize payment via a debit from your checking account for no fee, or credit card for a nominal fee, where applicable. For questions regarding your invoice contact: FRED SEARL 866-888-0990 fsearl@gosafeguard.com

Net 30. Late payments are subject to 1.5% per month. For W9 requests, send an email to W9ComplianceRequestsSafeguardUS@gosafeguard.com

PLEASE DETACH AND REMIT WITH YOUR PAYMENT. MAKE CHECKS PAYABLE TO SAFEGUARD BUSINESS SYSTEMS.

>>>>MAIL YOUR CHECK TO THE *NEW* ADDRESS BELOW<<<<

INVOICE NUMBER 9003268944
DUE DATE 1/4/2024
CUSTOMER ID 600104074
AMOUNT DUE (USD) \$ 366.91

SAFEGUARD BUSINESS SYSTEMS
LOCKBOX 229
P.O. BOX 7247
PHILADELPHIA PA 19170-0001



3 9003268944 0600104074 0000036691 6

We guarantee you will be completely satisfied with every Safeguard-brand product you purchase. If you are not completely satisfied once you receive the order, we'll do what it takes to make it right. While Safeguard takes care in the manufacture of such products, it is commercially impossible to detect all errors and imperfections. Therefore, no other warranty is given, and all affirmations, samples or models made or shown are for illustrative purposes only.

THE ABOVE WARRANTY IS EXPRESSLY IN LIEU OF ALL OTHER WARRANTIES AND REPRESENTATIONS, EXPRESSED OR IMPLIED, INCLUDING, BUT NOT LIMITED TO, IMPLIED WARRANTIES OF MERCHANTABILITY, FITNESS FOR A PARTICULAR PURPOSE AND NON-INFRINGEMENT. IN NO EVENT WILL SAFEGUARD BE LIABLE FOR ANY INDIRECT, SPECIAL, INCIDENTAL, CONSEQUENTIAL OR OTHER DAMAGES OF ANY NATURE OR DESCRIPTION RESULTING FROM ANY USE OR MISUSE OF ANY PRODUCT OR ANY ACT OR OMISSION BY SAFEGUARD, NOR WILL SAFEGUARD BE LIABLE FOR ANY BREACH OF WARRANTY (OR OTHER OBLIGATION BINDING UPON SAFEGUARD) IN AN AMOUNT GREATER THAN THE PURCHASE PRICE OF THE PRODUCT ACTUALLY PAID TO SAFEGUARD.

Title and risk of loss to products shall be deemed to pass to purchaser at point of shipment.

Safeguard conducts business in the state in which the products are shipped and is therefore required to collect appropriate sales and use taxes.

Other terms and conditions may apply. Please visit our website, GoSafeguard.com, for more details.

©2020 Safeguard Business Systems, Inc. Safeguard and the centurion head are registered trademarks of Safeguard Business Systems, Inc. All other logos are the intellectual property of their respective owners.

▶ 14954058 Stone Gate Cdd 1020 Malibu Way Homestead FL 33033



536.011
001

Invoice date: Dec 13, 2023 Service period: Jan 1 - Jan 31, 2024

Your total due is: Due by:
\$63.79 Jan 2, 2024

Your Bill at-a-glance

Previous Balance	\$63.79
Payments and Adjustments	-\$63.79
Current Charges	\$63.79
Taxes and Fees	\$0.00

Total Due \$63.79

Would you like more detail? See the back of the bill for your account activity and charges.

Message from ADT

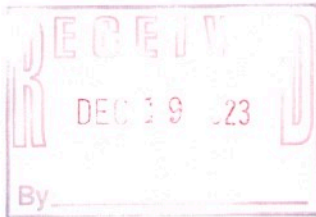

DID YOU KNOW?

MyADT.com gives you instant access to your account 24/7, so you can get things done - without needing to talk to an ADT agent.

Here are 5 of the many convenient features you'll want to try:



BILLING

1. Enroll in EasyPay® automated monthly payments.
2. Make a one-time payment in just a few clicks.
3. Easily check your billing statement and manage your payment method.



SYSTEM SUPPORT

4. Check or reschedule your service appointment without having to call.
5. Get troubleshooting and support for your Wi-Fi, cameras, panel, sensors and batteries.



Scan this QR code to register at i.adt.com/regmyadt



Brilliantly Safe™



ADT
452 Sable Blvd Unit G
Aurora, CO 80011

6230 0020 NO RP 13 12132023 NNNNNNNY 01 009079 0027

STONE GATE CDD
2300 GLADES RD STE 410
BOCA RATON FL 33431-7386

Account Number	14954058
Due Date	Jan 2, 2024
Amount Due	\$63.79

Amount Enclosed \$ _____

Please send payment to:

ADT SECURITY SERVICES
PO BOX 371878
PITTSBURGH, PA 15250-7878

Please detach and submit this slip with your payment. Do not send cash. Please write your customer Account Number on your check or money order and make payable to: ADT.



00014954058000000000000001212230000000000000063799

Your account number: **14954058** Security provided for: Stone Gate Cdd Your ADT system is located at: 1020 Malibu Way Homestead FL 33033

📍 Is your billing information incorrect? You can change it on MyADT.com.

Your Account Activity

Previous Balance	\$63.79
Payments and Adjustments	
Payment Received - Thank You	Nov 28, 2023
	-\$63.79
Current Charges	
RECURRING CHARGES	
Services	
Invoice Number 1034050642	Jan 1 - Jan 31, 2024
	\$63.79
Total Non-taxable Charges	\$63.79
Total Due to be paid by Jan 2, 2024	\$63.79

◀ Any balance left from previous billing periods
 ◀ All payments and adjustments received from you during billing period

About your Services: Cellguard Monitoring, Burglar Alarm Monitoring, Pulse Remote Internet Access, Quality Service Plan



💬 Have questions? Chat with us at MyADT.com.

📄 Pay your bill online at MyADT.com.

* Taxable charges



Thinking of moving?

Life changes, but your security provider doesn't have to. Scan the barcode below or visit i.adt.com/safemove to learn how we can help you have a new home with no worries.



Prepare for storm season

It's never too early to be ready for weather events. Start your safety plan with a quick checklist.

- Build an emergency supply kit and know where to shelter or evacuate.
- Remove damaged trees, limbs and other debris from your property.
- Secure gutters, windows and doors.
- Lost power? Low-battery alerts usually clear on their own 24-48 hrs. after power is restored.

Need ADT system help after a storm or power outage?

Scan the QR code to the right, or go to i.adt.com/storm



When you provide a check as payment, you authorize us either to use information from your check to make a one-time electronic fund transfer from your account or to process the payment as a check transaction. When we use information from your check to make an electronic fund transfer, funds may be withdrawn from your account as soon as the same day we receive your payment, and you will not receive your check back from your financial institution.
 ©2023 ADT LLC dba ADT Security Services. All rights reserved. ADT, the ADT logo, 800.ADT.ASAP and the product/service names listed in this document are marks and/or registered marks. Unauthorized use is strictly prohibited. License information available at www.ADT.com or by calling 800.ADT.ASAP. CA ACO7155, 974443; PPO17232; FL EF0001121; LA F1639, F1640, F1643, F1654, F1655; MA 172C; NC Licensed by the Alarm Systems Licensing Board of the State of North Carolina 7535P2, 7561P2, 7562P10, 7563P7, 7565P1, 7566P9; NY 12000305615; PA 090797. The ADT Security Corporation dba ADT Patrol, 21171 S. Western Ave. Torrance, CA 90501, Lic. No. PPO 120288. **MS 15019511**

INVOICE

UNUS Property Management LLC
3560 NE 11th Dr
Homestead, FL 33033

manager@unusmgmt.com
+1 (239) 789-7263



STONEGATE CDD

Bill to
GENERAL MANAGER
STONEGATE CDD
1020 Malibu Way
Homestead, FL 33033 USA

537.350 - \$2,560.00
537.350 - \$2,388.86
537.200 - \$71.66
536.003 - \$118.90
536.011 - \$250.02
001

Invoice details

Invoice no.: 1135
Terms: Due on receipt
Invoice date: 12/20/2023
Due date: 12/20/2023

#	Date	Product or service	SKU	Qty	Rate	Amount
1.		Management Hours Special Events Extra Hours Management & Staff :: Christmas Events 2023 Booking# 537.350		128	\$20.00	\$2,560.00
2.		Store Receipts Bookings 537.200, 536.003, 536.011, 537.350,		1	\$2,829.44	\$2,829.44

Total **\$5,389.44**

Ways to pay



Pay invoice



Final Details for Order #113-0099978-1103451

[Print this page for your records.](#)

Order Placed: November 29, 2023

Amazon.com order number: 113-0099978-1103451

Order Total: \$1,275.47

Shipped on November 29, 2023

Items Ordered

1 of: *Liliful 48 Pcs Christmas Glow Sticks Bulk 11.8 x 1.6 Inch Candy Cane Striped Led Foam Sticks LED Cheer Light up Sticks Glow in The Dark Party Supplies for Christmas Weddings Birthdays Raves* **Price**
\$65.99

Sold by: Xianewqia ([seller profile](#))

Supplied by: Xianewqia ([seller profile](#))

Condition: New

1 of: *Ring Pop Bulk holiday Candy Lollipop Variety Party Pack - 50 Count Lollipops w/ Assorted Flavors - Candy For Birthdays, Party Favors, Stocking Stuffers, holiday Gift Exchange* **Price**
\$21.99

Sold by: Amazon.com Services LLC

Supplied by: Other

Condition: New

537.350

Shipping Address:

Victor Castro
3560 NE 11TH DR
HOMESTEAD, FL 33033-5564
United States

Shipping Speed:

FREE Prime Delivery

Shipped on November 29, 2023

Items Ordered

1 of: *Liliful 48 Pcs Christmas Glow Sticks Bulk 11.8 x 1.6 Inch Candy Cane Striped Led Foam Sticks LED Cheer Light up Sticks Glow in The Dark Party Supplies for Christmas Weddings Birthdays Raves* **Price**
\$65.99

Sold by: Xianewqia ([seller profile](#))

Supplied by: Xianewqia ([seller profile](#))

Condition: New

3 of: *Ring Pop Bulk holiday Candy Lollipop Variety Party Pack - 50 Count Lollipops w/ Assorted Flavors - Candy For Birthdays, Party Favors, Stocking Stuffers, holiday Gift Exchange* **Price**
\$21.99

Sold by: Amazon.com Services LLC

Supplied by: Other

Condition: New

Shipping Address:

Victor Castro
3560 NE 11TH DR
HOMESTEAD, FL 33033-5564
United States

Shipping Speed:
FREE Prime Delivery

Shipped on November 29, 2023

Items Ordered

	Price
1 of: <i>Liliful 48 Pcs Christmas Glow Sticks Bulk 11.8 x 1.6 Inch Candy Cane Striped Led Foam Sticks LED Cheer Light up Sticks Glow in The Dark Party Supplies for Christmas Weddings Birthdays Raves</i>	\$65.99
Sold by: Xianewqia (seller profile)	
Supplied by: Xianewqia (seller profile)	

Condition: New

1 of: <i>Ring Pop Bulk holiday Candy Lollipop Variety Party Pack - 50 Count Lollipops w/ Assorted Flavors - Candy For Birthdays, Party Favors, Stocking Stuffers, holiday Gift Exchange</i>	\$21.99
Sold by: Amazon.com Services LLC	
Supplied by: Other	

Condition: New

Shipping Address:

Victor Castro
3560 NE 11TH DR
HOMESTEAD, FL 33033-5564
United States

Shipping Speed:
FREE Prime Delivery

Shipped on November 30, 2023

Items Ordered

	Price
1 of: <i>Liliful 48 Pcs Christmas Glow Sticks Bulk 11.8 x 1.6 Inch Candy Cane Striped Led Foam Sticks LED Cheer Light up Sticks Glow in The Dark Party Supplies for Christmas Weddings Birthdays Raves</i>	\$65.99
Sold by: Xianewqia (seller profile)	
Supplied by: Xianewqia (seller profile)	

Condition: New

1 of: <i>Ring Pop Bulk holiday Candy Lollipop Variety Party Pack - 50 Count Lollipops w/ Assorted Flavors - Candy For Birthdays, Party Favors, Stocking Stuffers, holiday Gift Exchange</i>	\$21.99
Sold by: Amazon.com Services LLC	
Supplied by: Other	

Condition: New

Shipping Address:

Victor Castro
3560 NE 11TH DR
HOMESTEAD, FL 33033-5564
United States

Shipping Speed:
FREE Prime Delivery

Shipped on November 30, 2023**Items Ordered**

12 of: *Christmas Squishy Toys, 26 PCS Christmas Mochi Squishies Bulk Toy for Girls Boys Kids, Christmas Party Favors, Christmas Fidget Sensory Goodie Bags Filler Gifts Decorations* **Price**
\$9.99

Sold by: Liam & Ava ([seller profile](#))

Supplied by: Liam & Ava ([seller profile](#))

Condition: New

Shipping Address:

Victor Castro
3560 NE 11TH DR
HOMESTEAD, FL 33033-5564
United States

Shipping Speed:

FREE Prime Delivery

Shipped on December 5, 2023**Items Ordered**

8 of: *WELLVO Christmas Drawstring Gift Bags for Kids 16 Pcs Christmas Goodie Bags Christmas Bags for Gifts with Drawstring Christmas Stocking Stuffers Party Favors Large Christmas Gift Bags 17 X 13In* **Price**
\$9.99

Sold by: wellvo ([seller profile](#)) | Product question? [Ask Seller](#)

Supplied by: wellvo ([seller profile](#))

Condition: New

Shipping Address:

Victor Castro
3560 NE 11TH DR
HOMESTEAD, FL 33033-5564
United States

Shipping Speed:

FREE Prime Delivery

Shipped on December 4, 2023**Items Ordered**

9 of: *WELLVO Christmas Drawstring Gift Bags for Kids 16 Pcs Christmas Goodie Bags Christmas Bags for Gifts with Drawstring Christmas Stocking Stuffers Party Favors Large Christmas Gift Bags 17 X 13In* **Price**
\$9.99

Sold by: wellvo ([seller profile](#)) | Product question? [Ask Seller](#)

Supplied by: wellvo ([seller profile](#))

Condition: New

Shipping Address:

Victor Castro
3560 NE 11TH DR
HOMESTEAD, FL 33033-5564

United States

Shipping Speed:
FREE Prime Delivery

Shipped on November 30, 2023

Items Ordered

5 of: *MCPINKY 64PCS Christmas Slap Bracelets, Slap Bracelets Bulk Snap Bracelets for Kids Christmas Stocking Stuffers Christmas Party Favors Classroom Gift Exchange*

Price
\$7.99

Sold by: MCPinky ([seller profile](#))
Supplied by: MCPinky ([seller profile](#))

Condition: New

Shipping Address:

Victor Castro
3560 NE 11TH DR
HOMESTEAD, FL 33033-5564
United States

Shipping Speed:
FREE Prime Delivery

Shipped on November 30, 2023

Items Ordered

9 of: *SEVEN STYLE 16 PCS Holiday Glasses,Cute Christmas Glasses Frames,Great Fun and Festive for Christmas Party Favors Holiday Favors Christmas photos booth*

Price
\$16.55

Sold by: ZYTJ ([seller profile](#))
Supplied by: ZYTJ ([seller profile](#))

Condition: New

Shipping Address:

Victor Castro
3560 NE 11TH DR
HOMESTEAD, FL 33033-5564
United States

Shipping Speed:
FREE Prime Delivery

Shipped on November 30, 2023

Items Ordered

10 of: *SEVEN STYLE 16 PCS Holiday Glasses,Cute Christmas Glasses Frames,Great Fun and Festive for Christmas Party Favors Holiday Favors Christmas photos booth*

Price
\$16.55

Sold by: ZYTJ ([seller profile](#))
Supplied by: ZYTJ ([seller profile](#))

Condition: New

Shipping Address:

Victor Castro

3560 NE 11TH DR
 HOMESTEAD, FL 33033-5564
 United States

Shipping Speed:

FREE Prime Delivery

Shipped on December 1, 2023**Items Ordered****Price**

1 of: *Liliful 48 Pcs Christmas Glow Sticks Bulk 11.8 x 1.6 Inch Candy Cane Striped Led Foam Sticks LED Cheer Light up Sticks Glow in The Dark Party Supplies for Christmas Weddings Birthdays Raves* \$65.99
 Sold by: Xianewqia ([seller profile](#))
 Supplied by: Xianewqia ([seller profile](#))

Condition: New

2 of: *WELLVO Christmas Drawstring Gift Bags for Kids 16 Pcs Christmas Goodie Bags Christmas Bags for Gifts with Drawstring Christmas Stocking Stuffers Party Favors Large Christmas Gift Bags 17 X 13In* \$9.99
 Sold by: wellvo ([seller profile](#)) | Product question? [Ask Seller](#)
 Supplied by: wellvo ([seller profile](#))

Condition: New

Shipping Address:

Victor Castro
 3560 NE 11TH DR
 HOMESTEAD, FL 33033-5564
 United States

Shipping Speed:

FREE Prime Delivery

Shipped on December 2, 2023**Items Ordered****Price**

1 of: *Liliful 48 Pcs Christmas Glow Sticks Bulk 11.8 x 1.6 Inch Candy Cane Striped Led Foam Sticks LED Cheer Light up Sticks Glow in The Dark Party Supplies for Christmas Weddings Birthdays Raves* \$65.99
 Sold by: Xianewqia ([seller profile](#))
 Supplied by: Xianewqia ([seller profile](#))

Condition: New

Shipping Address:

Victor Castro
 3560 NE 11TH DR
 HOMESTEAD, FL 33033-5564
 United States

Shipping Speed:

FREE Prime Delivery

Payment information**Payment Method:**

Visa ending in 0812

Item(s) Subtotal: \$1,191.97

Shipping & Handling: \$0.00

Total before tax: \$1,191.97

Estimated tax to be collected: \$83.50

Grand Total:\$1,275.47

Billing address

Victor Castro
3560 NE 11TH DR
HOMESTEAD, FL 33033-5564
United States

Credit Card transactions

Visa ending in 0812: December 5, 2023: \$181.73

Visa ending in 0812: December 2, 2023: \$70.61

Visa ending in 0812: December 1, 2023: \$21.38

Visa ending in 0812: December 1, 2023:\$1,001.75

To view the status of your order, return to [Order Summary](#).

[Conditions of Use](#) | [Privacy Notice](#) © 1996-2023, Amazon.com, Inc. or its affiliates

537.200



Homestead - 786-650-3315
2551 NE 9th Ct
Homestead, Florida 33033-4724
12/15/2023 07:42 PM



STATIONERY & OFFICE SUPPLIES

081062191	TAPE	T	\$14.98
	2 @ \$7.49 ea		
081220076	FISKARS	T	\$9.99
051099966	WONDERSHOP	T	\$6.00
051090278	WONDERSHOP	T	\$6.00
051095367	WONDERSHOP	T	\$10.00
	2 @ \$5.00 ea		
051098430	WONDERSHOP	T	\$15.00
	3 @ \$5.00 ea		
051090167	WONDERSHOP	T	\$5.00

SUBTOTAL \$66.97

T = FL TAX 7.0000 on \$66.97 \$4.69

TOTAL \$71.66

*8612 MASTERCARD CHARGE \$71.66

AID: A0000000041010

MASTERCARD

AUTH CODE: 65253Z

WHEN YOU RETURN ANY ITEM, YOUR RETURN CREDIT WILL NOT INCLUDE ANY PROMOTIONAL DISCOUNT OR COUPON THAT APPLIED TO THE ORIGINAL ORDER.

REC#2-3349-3424-0166-7732-7 VCD#757-253-447

Help make your Target Run better.
Take a 2 minute survey about today's trip

informtarget.com

User ID: 7665 0657 6983

Password: 322 673

CUÉNTENOS EN ESPAÑOL

Please take this survey within 7 days



536.003

How does
get more done.

FLORIDA CITY STORE 6355 (786)243-9370
MANAGER ANNA FAGOT

6355 00051 98817 12/06/23 08:02 PM
SALE SELF CHECKOUT

030878268981 OUTDR TMER <A>
MYTOUCHSMART OUTDOOR DIGITAL TIMER 2
2@25.98 51.96

091198020796 JAMB BRACKET <A>
BIFOLD DR BOTTOM PIVOT JAMB BRACKET
2@4.93 9.86

091198001207 DOOR PIVOT <A>
BIFOLD CLOSET DOOR TOP PIVOT 4.67

091198010186 BOTTOM PIVOT <A>
3/8" BOTTOM PIVOT FOR BIFOLD DOORS 4.67

6972993532896 WORK LIGHT <A>
HUSKY 1000-LUMEN PORTABLE WORK LIGHT
2@19.98 39.96

SUBTOTAL 111.12

SALES TAX 7.78

TOTAL \$118.90

XXXXXXXXXXXX0812 DEBIT USD\$ 118.90

AUTH CODE 000636

Chip Read

AID A00000000980840

Verified By PIN

US DEBIT

PRO XTRA MEMBER STATEMENT

PRO XTRA ###-###-7263 SUMMARY
THIS RECEIPT P0/JOB NAME: electrical suppl
ies

2023 PRO XTRA SPEND 12/05: \$9,827.74

Get the CREDIT LINE your business needs
PLUS earn Perks 4X FASTER when you join
Pro Xtra, register, & use your Pro Xtra
Credit Card. Apply and SAVE UP TO \$100.
Learn more at homedepot.com/credit

6355 12/06/23 08:02 PM



6355 51 98817 12/06/2023 5090

RETURN POLICY DEFINITIONS
POLICY ID DAYS POLICY EXPIRES ON
A 1 90 03/05/2024

DID WE NAIL IT?

Take a short survey for a chance TO WIN
\$100 HOME DEPOT GIFT CARD



536.011
**How doers
 get more done.**

FLORIDA CITY STORE 6355 (786)243-9370
 MANAGER ANNA FAGOT

6355 00036 75014 12/13/23 02:40 PM
 SALE CASHIER ALESIA

019800001094 DRNOMAXCRGAL <A> 11.98
 DRANO MAX GEL CLOG REMOVER 128 OZ
 NLP Savings \$4.50
 041785999974 EASYWRING SP <A> 14.97
 EASYWRING SPIN MOP REFILL 2-PACK
 041333030333 COPPERTOP AA <A> 14.87
 DURACELL AAA 18-PACK
 NLP Savings \$2.00
 039800068194 AA 36 PACK <A> 20.87
 ENERGIZER MAX AA 36-PACK
 887480141207 MASON LINE <A> 5.97
 250' MASON LINE REFILL NYLON WHITE
 629219841510 11INORNGESTK <A>
 11-INCH ORANGE PLASTIC GROUND STAKE
 12@2.98 35.76
 008236880519 #66HOME <A>
 #66 HOME KEY
 2@5.97 11.94
 008236776508 66KEY LT RED <A>
 #66 KEYLIGHT - RED
 2@6.97 13.94
 038902090102 66OWLKEY <A>
 #66 OWL KEY
 2@5.97 11.94

SUBTOTAL 142.24
 SALES TAX 9.96
 TOTAL \$152.20

XXXXXXXXXXXX8612 MASTERCARD
 USD\$ 152.20
 AUTH CODE 14259Z/5363365 TA
 Chip Read
 AID A0000000041010 MASTERCARD

PRO XTRA MEMBER STATEMENT

PRO XTRA ###-###-7263 SUMMARY
 THIS RECEIPT PO/JOB NAME: supplies

2023 PRO XTRA SPEND 12/12: \$10,057.77

Get the CREDIT LINE your business needs
 PLUS earn Perks 4X FASTER when you join
 Pro Xtra, register, & use your Pro Xtra
 Credit Card. Apply and SAVE UP TO \$100.
 Learn more at homedepot.com/credit

6355 12/13/23 02:40 PM



6355 36 75014 12/13/2023 9967

RETURN POLICY DEFINITIONS
 POLICY ID DAYS POLICY EXPIRES ON
 A 1 90 03/12/2024

DID WE NAIL IT?



536.011
**How doers
 get more done.**

FLORIDA CITY STORE 6355 (786)243-9370
 MANAGER ANNA FAGOT

6355 00027 96464 11/30/23 07:00 PM
 SALE CASHIER THALLIA

044600324296 CLXGERBLC121 <A>
 CLX GERMICIDAL BLEACH 121OZ
 4@9.48 37.92
 041911050203 SWGLSAERO4PK <A>
 SPRAYWAY GLASS FOAM AERO 190Z 4PK
 4@9.88 39.52
 037000695257 EXTRA DURABL
 MR CLEAN ERASER EXTRA POWER 10CT 13.96

SURTOTAL 91.42
 SALES TAX 6.40
 TOTAL \$97.82

XXXXXXXXXXXX0812 DEBIT
 USD\$ 97.82

AUTH CODE 000824
 Chip Read Verified By PIN
 AID A0000000980840 US DEBIT

PRO XTRA MEMBER STATEMENT

PRO XTRA ###-###-7263 SUMMARY
 THIS RECEIPT PO/JOB NAME: supplies

2023 PRO XTRA SPEND 11/29: \$9,706.34

Get the CREDIT LINE your business needs
 PLUS earn Perks 4X FASTER when you join
 Pro Xtra, register, & use your Pro Xtra
 Credit Card. Apply and SAVE UP TO \$100.
 Learn more at homedepot.com/credit

6355 11/30/23 07:00 PM



6355 27 96464 11/30/2023 8267

RETURN POLICY DEFINITIONS
 POLICY ID DAYS POLICY EXPIRES ON
 A 1 90 02/28/2024

DID WE NAIL IT?

Take a short survey for a chance to WIN
 A \$5,000 HOME DEPOT GIFT CARD

Opine en español

www.homedepot.com/survey

User ID: HLL 199572 193244
 PASSWORD: 23580 193217

Entries must be completed within 14 days
 of purchase. Entrants must be 18 or
 older to enter. See complete rules on
 website. No purchase necessary.



537.350

650 SE 8th Street
Homestead, FL

Club Mgr. Angela Acosta

Club:170 Reg:40 Trans:9959

Cashier:400 12/16/23 11:36am

*****:*****:*****

*** MEMBERSHIP ID. 17042029142 ***

*** MEMBERSHIP EXPIRES ON 08/24 ***

*****:*****:*****

4180047910 WELCH 24/10Z 149.90 T

10 @ 14.99

7343050113 ZEPH WATER 63.92 N

8 @ 7.99

20107400000 CHUNK COOKIE 9.99 N

20107400000 CHUNK COOKIE 9.99 N

20107400000 CHUNK COOKIE 9.99 N

20107400000 CHUNK COOKIE 9.99 N

20107400000 CHUNK COOKIE 9.99 N

20107400000 CHUNK COOKIE 9.99 N

20107400000 CHUNK COOKIE 9.99 N

20107400000 CHUNK COOKIE 9.99 N

20107400000 CHUNK COOKIE 9.99 N

20107400000 CHUNK COOKIE 9.99 N

**** SUBTOTAL 313.72

FL 7% Tax 10.49

**** TOTAL 324.21

*****:8612 ENTRY: C

Purchase 00 APPROVED

AUTH 14235Z

TERMINAL NUMBER 78073017040

12/16/23 11:38am 170 40 9959 400

MASTERCARD

HomeGoods

HOMESTEAD TOWNE SQUARE
915 N HOMESTEAD BLVD
HOMESTEAD, FL 33030
United States
305-242-7214

537.350

REGULAR SALE

24 - DEC PILLOWS	238669	\$24.99	T
24 - DEC PILLOWS	242772	\$24.99	T
24 - DEC PILLOWS	244236	\$24.99	T
24 - DEC PILLOWS	244240	\$24.99	T
24 - DEC PILLOWS	255269	\$24.99	T
24 - DEC PILLOWS	244236	\$24.99	T
27 - SEASONAL LINEN	062517	\$29.99	T
27 - SEASONAL LINEN	062517	\$29.99	T
26 - THROWS	067054	\$16.99	T
26 - THROWS	088949	\$19.99	T

Subtotal \$246.90
FL 7.000% Sales Tax \$17.28

Total \$264.18

MASTERCARD \$264.18

TRANSACTION RECORD

*****8612
PURCHASE
EXPIRES **/** CHIP
AUTH# 16621Z
AID A0000000041010
APPLICATION LABEL MASTERCARD
No CVM Performed
83478 64325 12-15-2023 18:58:30
APPROVED

Change \$0.00

HOMEGOODS VALUES YOUR FEEDBACK!!!!

Tell us what you think about
your store visit today and
enter a monthly drawing to win a
\$500 HomeGoods Gift Card!

Dantes Bounce House LLC

Invoice

Dantes Bounce House LLC

13280 sw 131 street
Miami Fl 33187
US

www.dantesbouncehouse.net
305 965 9975
Dantesbounce@yahoo.com

BILL TO

Malibu bay
1020 Malibu way homestead Fl 33033
manager@unusmgmt.com
239 789 7263
4-7pm

Invoice #

1266

Date

Dec 16, 2023

Due date

Dec 16, 2023

Item	Quantity	Price	Amount
Trackless train	3	\$175.00	\$525.00

Payment Instruction

Zelle
Card
Cash

Subtotal

\$525.00

Total

\$525.00

Amount Due

\$525.00**PAID**

Must return equipment in same condition at drop off. \$100 late fee for payments. Tables must be cleaned and chairs stacked ready for pick up. Set up is extra. Tip is not included. Adult supervision at all times. No horse playing. No hanging on nets. No gum food drinks in bounce house. No shoes in bounce house. Dantes bounce house is not responsible for any type of injury. Customers assume full responsibility for equipment and guest using the equipment. During bad weather conditions turn off equipment. Customer takes full responsibility for damage or stolen equipment.

Malibu bay

(/ /)

INVOICE

UNUS Property Management LLC
3560 NE 11th Dr
Homestead, FL 33033

manager@unusmgmt.com
+1 (239) 789-7263



STONEGATE CDD

Bill to

GENERAL MANAGER
STONEGATE CDD
1020 Malibu Way
Homestead, FL 33033 USA

Invoice details

Invoice no.: 1136
Terms: Due on receipt
Invoice date: 12/27/2023
Due date: 12/27/2023

#	Date	Product or service	SKU	Qty	Rate	Amount
1.		Management Service Monthly		1	\$20,872.19	\$20,872.19

Total **\$20,872.19**

Ways to pay



Pay invoice



305-773-5889
info@vividclearglass.com
www.vividclearglass.com

Vivid Clear Glass

536.003

Invoice

Bill To: Malibu Bay Clubhouse
info@malibubayclubhouse.com,
victor@malibubay.onmicrosoft.com
+1 (305) 247-8859

Invoice No: 1078
Date: 11/10/2023

Description	Quantity	Rate	Amount
Glass restoration services - Stains 6 windows - Hardwater stains Polish and seal. 1 technician x 1 day Service location: Kyle Malibu bay clubhouse 1020 Malibu way Homestead fl 33033	1	\$625.00	\$625.00*
Glass sealer and protector. 6 windows Clubhouse entrance To help prevent permanent water stains from occurring in the future. -Extreme Durability -Extreme Gloss -Hydraphobic Properties -Uv Protection -Self Cleaning Properties	6	\$35.00	\$210.00*

*Indicates non-taxable item

Payment Details

- We accept Credit Cards, ACH transfers, Checks

ACH transfer:

Account# 898101580042

Routing# 063100277

Zelle payment email:

diaz.pedro.luis.1978@gmail.com

Please make checks payable to:

Vivid Clear Glass LLC.

*Please mail all checks to:

P.O. BOX 330065 Miami, Fl. 33233.

- Thank you very much for your business!

Subtotal	\$835.00
Total	\$835.00
PAID	\$0.00

Balance Due \$835.00

Deposit due 11/06/2023 \$417.50



Photo 1



Photo 2



Photo 3



Photo 4



Photo 5



Photo 6



Photo 7



Photo 8



Photo 9



Armando Garcia Land Service INC
 16650 SW 203 AVE
 Miami, FL 33187 US
 (786) 298-7104
 armando-garcia-landservice@hotmail.com

Invoice

BILL TO

Stonegate CDD
 2300 Glades Rd. Ste. 410 W
 Boca Raton, FL 33431

537.460
001

INVOICE #	DATE	TOTAL DUE	DUE DATE	TERMS	ENCLOSED
763411	12/19/2023	\$850.00	01/18/2024	Net 30	

DESCRIPTION	QTY	RATE	AMOUNT
Trim. Trim behind the signs of Malibu Bay and pick up debris. Trim all the Spartina, Pick up coconut fallen branches & Palm Tree Fallen branches.	1	850.00	850.00

SUBTOTAL	850.00
TAX	0.00
TOTAL	850.00
BALANCE DUE	\$850.00



CONTRACT INVOICE

Mail Remittance To

ImageNet Consulting of Boca
Raton LLC
913 NORTH BROADWAY AVE
OKLAHOMA CITY, OK 73102
800.937.2647 Office
405.236.3334 Fax

Boca Raton Division
Fed ID 45-3028912
DUNS # 09-845-9357

Invoice #
INV774613

Terms
Net 10

536.007

Bill To: UM00:
UNUS MANAGEMENT
23200 GLADES RD SUITE 410W
BOCA RATON, FL 33431

Customer: UM00-001:
STONEGATE CDD
1020 NE 34TH AVE
HOMESTEAD, FL 33033

Customer #	Contract Number	P.O. Number	Invoice Date	Due Date
UM00	CONT2171-01		12/14/2023	12/24/2023
Invoice Remarks				

Contract Remarks

Summary:

Contract base rate charge for this billing period	\$0.00
Contract overage charge for the 11/20/2023 to 12/19/2023 overage period	\$2.83
Surcharge	\$0.42
	\$3.25

Detail:

Equipment included under this contract

HP/HP E776DNS MFP BASE

Number	Serial Number	Base Charge	Location
EQU41460	MXBCQ3H00R	\$0.00	STONEGATE CDD 1020 NE 34TH AVE HOMESTEAD, FL 33033 OFFICE

Item1

OFFICE

Meter Type	Meter Group	Begin Meter	End Meter	Total	Covered	Billable	Rate	Overage
PROFESSION	EQU41460 - PROFESS	1,930	1,939	9	0	9	0.057500	\$0.52
GENERAL OF	EQU41460 - GENERAL	345	347	2	0	2	0.011500	\$0.02
ACCENT	EQU41460 - ACCENT	641	641	0	0	0	0.011500	\$0.00
BW	EQU41460 - BW	7,708	7,907	199	0	199	0.011500	\$2.29
								\$2.83

Important:

To ensure proper credit to your account, please write your customer and invoice number on your check.

Credit card payments may incur a non-refundable convenience fee.

Disputes must be received in writing within 45 days from date of invoice.

Invoice SubTotal	\$3.25
Tax:	\$0.23
Invoice Total	\$3.48
Balance Due:	\$3.48



Stage Craft Scenery Design, Holiday Crafts, Special Events Coordinator,
 Special Effects, Costume Fabrication, Content Creator, Guest Speaker,
 Visual and Performing Artist, Happy DIY'er

18515 SW 360 Street Florida City, Florida 33034 Visit us on Instagram and Facebook for photos and info

magicartsstudiosllc@gmail.com 786-475-7725 @magicartsstudiosflorida
www.facebook.com/MagicArtsStudios

Attention to: Victor Castro
 Address: 920 NW Terrace, Homestead 3033
 Email: manager@UNUSmgmt.com
 Phone: [Click or tap here to enter text.](#)
 Organization: Malibu Bay Clubhouse
 Invoice#: 0011

Date: 12/18/2023
Quote: **Estimate:**

We accept checks, Cash App, credit cards and cash

537.350

Project Title Malibu Bay Christmas Party **DATE:** December 16th, 2023 3-7pm

Location: Malibu Bay Clubhouse

Project Description: Appearance by Santa Claus for guests meet, greet and photos 3pm - 7 pm.

Estimates may change due to supply variations. Quotes may or may not include labor for additional help as needed.

Service Description	Hr/Qty	Unit/Ea	Sub Total
Santa Claus Appearance fee	4	150.00	600.00
Includes theatrical grade Santa appearance, theme holiday greetings, photo session			
Click or tap here to enter text.			
Click or tap here to enter text.			
Click or tap here to enter text.			
Click or tap here to enter text.			
Click or tap here to enter text.			
Click or tap here to enter text.			
Click or tap here to enter text.			
Click or tap here to enter text.			
Click or tap here to enter text.			
Click or tap here to enter text.			
Click or tap here to enter text.			
Total			600.00

Thank you for your consideration! ☺

Over 30 years in the theater scenic design, fabricator, producer and organizer, holiday special effects, costumed characters. Past productions include: *In The Heights, Annie, A Christmas Carol, Lion King Jr, Aida, The Little Mermaid, Aladdin Jr, Legally Blonde Jr., Mamma Mia, Jekyll and Hyde. Westminster Christian Academy: West Side Story. Grease/ A Music Man- Homestead Senior High. Over 30 years as a Haunted House designer and builder for Homestead ARB, Homestead PD PAL, Centro Villas Halloween, Malibu Bay.*

Francisco "Frankie" Navarro, CEO MagicArts Studios LLC. L22000016048

★Small Business Owner and US Veteran Owned Business★



True Blue Pools
18495 Dixie Hwy
Cutler Bay, FL 33157 US
(305)562-7010x1
truebluepoolscontracting@gmail.com
<http://www.truebluepoolscontracting.com/>

INVOICE

BILL TO
Stonegate CDD
1020 Malibu Way
Homestead, FL 33033

INVOICE # 22-1359a
DATE 12/15/2023
DUE DATE 12/15/2023
TERMS Due on receipt

ACTIVITY	QTY	RATE	AMOUNT
New Swimming Pool Construction:Engineering Plans Engineering Plans for bidding process. Recreate and make new code adjustment for Malibu community pool for Stonegate CDD. Signed and sealed	1	4,500.00	4,500.00

Thank you for the opportunity of serving you. It has been our pleasure to provide you with excellent service. Please find attached your invoice. We appreciate prompt payment.
Thank you.

BALANCE DUE

\$4,500.00

STONEGATE
COMMUNITY DEVELOPMENT DISTRICT

MINUTES

DRAFT

**MINUTES OF MEETING
STONEGATE
COMMUNITY DEVELOPMENT DISTRICT**

The Board of Supervisors of the Stonegate Community Development District held Public Hearings and a Regular Meeting on September 13, 2023 at 11:00 a.m., at the Malibu Bay Clubhouse, 1020 NE 34th Avenue, Homestead, Florida 33033.

Present at the meeting were:

Joe McGuinness	Chair
Alberto Eiras	Vice Chair
Mariela Figueroa	Assistant Secretary
Arthur Goessel	Assistant Secretary
Yoniel Boza	Assistant Secretary

Also present were:

Daniel Rom	District Manager
Michael Pawelczyk	District Counsel
Liza Smoker	Billing, Cochran, Lyles, Mauro & Ramsey, P.A.
Juan Alvarez	District Engineer
Victor Castro (via telephone)	Field Operations
Jennifer Puerto	Resident
Hernan Chavez	Resident
Manuel Quinones	Resident

FIRST ORDER OF BUSINESS

Call to Order/Roll Call

Mr. Rom called the meeting to order at 11:02 a.m. All Supervisors were present.

SECOND ORDER OF BUSINESS

Public Comments: non-agenda items

There were no public comments.

THIRD ORDER OF BUSINESS

**Discussion: Board Direction for Pool
Renovation RFP**

41 Mr. Rom stated Staff is coordinating with True Blue Pools (True Blue), the pool
42 maintenance vendor, to secure a proposal for pool renovations. True Blue expressed interest in
43 performing the work but efforts by True Blue to provide a payment and performance bond, which
44 is required per Florida Statutes due to the value of the contract, were unsuccessful. Mr. Rom
45 asked for the Board's permission to advertise a formal Request for Proposals (RFP) for pool
46 renovations to generate further interest.

47 Ms. Figueroa asked for an estimated project timeline. Mr. Alvarez stated it could take
48 about ten weeks to award the contract and six months to put together a construction schedule.
49 Starting today, the pool renovation project would take a total of approximately nine months to
50 complete. He suggested including verbiage in the RFP package stating that the pool equipment
51 is separate from the contract and engaging a contractor to do everything except for the items
52 that only True Blue can do, excluding the mechanical plans for the pool equipment, and allowing
53 True Blue to enter into a separate contract to facilitate that component. Mr. Castro stated the
54 CDD has a company to do the pool, it just needs a vendor to construct the retaining wall. Mr.
55 Pawelczyk stated, legally, it will be necessary to appoint/engage an individual to coordinate the
56 different contractors working on the project.

57 Discussion ensued regarding construction permits, waiving the performance bond
58 requirement, verbiage in the RFP package, the full RFP, True Blue, equipment plans, whether to
59 separate the pool project into two or three components, a prime/general contractor and the
60 project timeline.

61 Mr. McGuinness expressed frustration that upgrading the pool has been ongoing for two
62 to three years and that it might take another nine months for the work to officially commence.
63 He thinks the Board needs to consider a plan B, such as splitting the work into three projects.

64 Mr. Alvarez stated the project can be split in two parts, one being pool equipment and
65 the pool water and the other being the pavers and the wall, but not into three parts. The RFP is
66 going to be publicly bid but a "plan B" might include doing the pool work and putting the
67 equipment in a place that does not depend on building the wall. He suggested engaging a prime
68 contractor and allowing True Blue to do the pool and the mechanical, including obtaining the
69 necessary permit.

70 The Board and Staff discussed soliciting proposals from vendors, the bid process, what to
71 do if the CDD cannot find a prime contractor, eliminating the deck expansion portion and a not-
72 to-exceed amount for the mechanical plans.

73

74 **On MOTION by Mr. McGuinness and seconded by Mr. Goessel, with all in favor,**
75 **allotting a not-to-exceed payment of \$25,000 to True Blue Pools to provide**
76 **plans, subject to True Blue issuing a credit to the CDD for the plans if the CDD**
77 **enters into an agreement with them to do the pool equipment work, was**
78 **approved.**

79

80

81 The Board directed Staff to advertise an RFP for a General Contractor based on the plans
82 and utilizing the expertise of the District Engineer.

83 Asked about the proposal timing, Mr. Rom stated Staff must first obtain the plans from
84 True Blue and then produce and transmit the RFP to the newspapers, which needs a lead time of
85 10 days. Mr. McGuinness lamented that the project will not be completed by the summer of
86 2024, based on the project timeline, and that the Clubhouse will be closed all summer. Mr. Rom
87 stated the Board will be apprised of when the RFP packages go out and Staff will provide periodic
88 updates.

89

90 **FOURTH ORDER OF BUSINESS**

**Consideration of Armando Garcia Land
Services, Inc., Specifications and Estimate
for Updated FY2023 Lawn Maintenance
Services**

91

92

93

94

95 Mr. Rom distributed a proposal from Armando Garcia Land Services, Inc., which includes
96 plant trimmings for Lakes 3 and 5 for \$27,150, and a revised total of \$128,772.90.

97 Mr. Castro recapped an opinion by Mr. Garcia that it is in the CDD's best interest to have
98 the lakes trimmed a minimum of three times per year, including cleaning out the plant beds every
99 time that work is performed. He explained that the \$27,150 is the yearly total for three cuts for
100 the two lakes; the price could increase if there is one additional cut, depending on rainfall and
101 how the fiscal year falls. Trimming is necessary to keep the plants at a certain size, ensure fullness
102 and deter weed growth, which suffocates the plants.

103 Discussion ensued regarding the contract, cost increase and if it is necessary to have
104 plants around the lakes.

105

106 **On MOTION by Mr. McGuinness and seconded by Mr. Eiras, with all in favor, the**
107 **Armando Garcia Land Services, Inc., proposal, in the amount of \$101,612.90, as**
108 **presented, including ad-hoc approval by the District Manager and Operations**
109 **Manager for plant trimmings at Lakes 3 and 5, only as requested, was approved.**

110

111

112 **FIFTH ORDER OF BUSINESS**

**Public Hearing on Adoption of Fiscal Year
2023/2024 Budget**

113

114

115 **A. Proof/Affidavit of Publication**

116 **B. Consideration of Resolution 2023-07, Relating to the Annual Appropriations and**
117 **Adopting the Budget for the Fiscal Year Beginning October 1, 2023, and Ending**
118 **September 30, 2024; Authorizing Budget Amendments; and Providing an Effective Date**

119 Mr. Rom presented Resolution 2023-07 and reviewed the proposed Fiscal Year 2024
120 budget. The only change since the last meeting was the allocation of \$160,000 that was set aside
121 for a playground, to the Unassigned Fund Balance, as directed by the Board.

122

123 **On MOTION by Mr. McGuinness and seconded by Ms. Figueroa, with all in favor,**
124 **the Public Hearing was opened.**

125

126

127 Resident Manuel Quinones voiced his concerns about too many cost increases and asked
128 the Board to consider delaying the playground project one year and using those funds to address
129 pressing issues, such as the pool.

130 Discussion ensued regarding the CDD's list of priorities, the Clubhouse, lakes, playground,
131 pool and gym access and unassigned fund balance.

132 Mr. Rom read an email from resident Rosa Doran into the record, as follows:

133 "I would like to voice my concern about the CDD meeting being held at a time when most
134 residents are working. I noticed the proposed increase on the tax bill yet have not received the

135 budget for Malibu Bay. I would like my disapproval for any increase to be noted in the minutes
136 for this meeting. Thank you in advance.”

137 Mr. Rom stated he responded to an email received from resident Jose Lopez regarding
138 the increase. Regarding the timing of the meetings, Mr. Rom stated the Board held a meeting in
139 August to give residents the opportunity to voice their opinions pertaining to the budget and only
140 a handful of residents attended. Meetings are scheduled at least six times per year beginning at
141 6:30 p.m. This meeting is being held at 11:30 a.m., due to the conflicting schedule of a Supervisor
142 who does not have normal working hours and because the budget Public Hearing meeting must
143 be held within a certain week to utilize the County Property Appraiser’s office for assessments.

144

**On MOTION by Mr. McGuinness and seconded by Ms. Figueroa, with all in favor,
the Public Hearing was closed.**

145

146

147

148

149

150

151

Mr. McGuinness discussed the assessment, the CDD’s challenges, items that must be
maintained, unassigned fund balance and the projects he would like to prioritize in the coming
year.

152

153

Discussion ensued regarding lake maintenance, pool upgrades and maintaining reserves
for future projects.

154

155

Mr. McGuinness asked for the following adjustments to be made to the Fiscal Year 2024
budget:

156

157

➤ General Fund Budget “Unassigned Fund balance – ending (projected)” line item: Change
to \$200,000

158

159

➤ O&M Assessment: Increase by \$182.52 per unit

160

161

162

163

164

165

**On MOTION by Mr. Eiras and seconded by Ms. Figueroa, with all in favor,
Resolution 2023-07, Relating to the Annual Appropriations and Adopting the
Budget for the Fiscal Year Beginning October 1, 2023, and Ending September 30,
2024; as amended and such that the per unit assessment increase is not to
exceed \$182.50, Authorizing Budget Amendments; and Providing an Effective
Date, was adopted.**

166

167

168 **SIXTH ORDER OF BUSINESS** **Public Hearing to Hear Comments and**
169 **Objections on the Imposition of Special**
170 **Assessments for Operations and**
171 **Maintenance for Fiscal Year 2023/2024,**
172 **Pursuant to Florida Law**
173

- 174 **A. Proof/Affidavit of Publication**
- 175 **B. Consideration of Resolution 2023-08, Making a Determination of Benefit and Imposing**
176 **Special Assessments for Fiscal Year 2023/2024; Providing for the Collection and**
177 **Enforcement of Special Assessments; Certifying an Assessment Roll; Providing for**
178 **Amendments to the Assessment Roll; Providing a Severability Clause; and Providing an**
179 **Effective Date**

180

181 **On MOTION by Mr. McGuinness and seconded by Mr. Boza, with all in favor, the**
182 **Public Hearing was opened.**

183

184

185 No members of the public spoke.

186

187 **On MOTION by Mr. McGuinness and seconded by Ms. Figueroa, with all in favor,**
188 **the Public Hearing was closed.**

189

190

191 Mr. Rom presented Resolution 2023-08 and read the title.

192

193 **On MOTION by Mr. McGuinness and seconded by Mr. Boza, with all in favor,**
194 **Resolution 2023-08, Making a Determination of Benefit and Imposing Special**
195 **Assessments for Fiscal Year 2023/2024; Providing for the Collection and**
196 **Enforcement of Special Assessments; Certifying an Assessment Roll; Providing**
197 **for Amendments to the Assessment Roll; Providing a Severability Clause; and**
198 **Providing an Effective Date, was adopted.**

199

200

201 **SEVENTH ORDER OF BUSINESS** **Consent Agenda Items**

- 202
- 203 **A. Acceptance of Unaudited Financial Statements as of July 31, 2023**
- 204 **B. Approval of August 1, 2023 Regular Meeting Minutes**

205

206

207

On MOTION by Ms. Figueroa and seconded by Mr. Eiras, with all in favor, the Consent Agenda Items, as presented, were accepted and approved.

208

209

EIGHTH ORDER OF BUSINESS

Staff Reports

211

A. Operations Manager: UNUS Property Management

213 There was no report.

B. District Counsel: Billing, Cochran, Lyles, Mauro & Ramsey, P.A.

• 2023 Legislative Update

216 Mr. Pawelczyk presented a Legislative Memorandum from his firm and discussed the
217 ethics training requirement beginning January 2024. There is also a new requirement for
218 contracts to include punchlist costs and a ban on the use of prohibited applications on devices.

C. District Engineer: Alvarez Engineers, Inc.

220 There was no report.

D. District Manager: Wrathell, Hunt and Associates, LLC

• NEXT MEETING DATE: October 3, 2023 at 6:30 PM

○ QUORUM CHECK

224 The October meeting will likely be canceled.

225

NINTH ORDER OF BUSINESS

Supervisors' Requests

227

228 There were no Supervisors' requests.

229

TENTH ORDER OF BUSINESS

Adjournment

231

232

On MOTION by Ms. Figueroa and seconded by Mr. McGuinness, with all in favor, the meeting adjourned at 12:58 p.m.

235

236

237

238

[SIGNATURES APPEAR ON THE FOLLOWING PAGE]

239
240
241
242
243
244

Secretary/Assistant Secretary

Chair/Vice Chair

STONEGATE
COMMUNITY DEVELOPMENT DISTRICT

STAFF
REPORTS B

MEMORANDUM

TO: District Manager

FROM: Billing, Cochran, Lyles, Mauro & Ramsey, P.A.
District Counsel

DATE: January 19, 2024

RE: Required Ethics Training and Financial Disclosure

Ethics Training

This memorandum serves as a reminder that beginning January 1, 2024, elected and appointed commissioners of community redevelopment agencies and local officers of independent special districts are required to complete four (4) hours of ethics training annually. The training must address, at a minimum, s. 8, Art. II of the Florida Constitution (ethics for public officers and financial disclosure), the Code of Ethics for Public Officers and Employees, and the Florida Public Records Law and Open Meetings laws.

Deadlines & Recordkeeping

The deadline to complete training for this calendar year is December 31, 2024. There is no requirement to submit proof that you have completed the training. However, the Florida Commission on Ethics recommends that Supervisors maintain a record of all completed trainings, including the date and time of completion. This documentation may be useful if Supervisors are ever required to provide evidence of training completion. The training is a calendar year requirement and corresponds to the form year. Therefore, Supervisors will report their 2024 training when filling out their Form 1 for the 2025 year.

Links to Online Training

[Public Meetings and Public Records Law \(2-Hour Audio Presentation\)](#). This presentation is audio only and is offered by the Office of the Attorney General. This presentation covers public records and Florida public records law. The presentation can be accessed for free. Completing this presentation will satisfy 2 of the 4 hours of required ethics training.

[State Ethics Laws for Constitutional Officers & Elected Municipal Officers](#). This training is presented by the Florida Commission on Ethics. The training is an overview of Florida's Ethics Code (Part III, Chapter 112, and Article II, Section 8, Florida Constitution) geared toward Constitutional Officers and Elected Municipal Officers. Topics covered include gifts, voting conflict, misuse of office, prohibited business relationships, conflicting employment relationships, revolving door, and Amendment 12. This presentation can be accessed for free. Completing this training will satisfy 2 of the 4 hours of required ethics training.

[State-Mandated Continuing Education in Ethics](#). This class is presented by the Florida League of Cities. The class covers Chapter 112 of Florida’s Ethics Code (2 Hours) and Florida Public Records and Public Meetings Law (2 Hours). To take this class, you must register for it, however there is no registration fee. Completing this class will meet your ethics training requirement.

[“4-Hour Ethics Course”](#). The “4-Hour Ethics Course” is available online and presented by the Florida Institute of Government. There are three sessions. Session 1 covers Florida’s Public Records Laws (1 hour), session 2 covers Florida Government in the Sunshine Law (1 hour), and session 3 covers Florida’s Ethics Laws (2 hours). The registration fee is \$79. Completing this entire course will meet your ethics training requirement.

[Sunshine Law, Public Records and Ethics for Public Officers and Public Employees 2023](#). This seminar is offered by the Florida Bar. This seminar covers sunshine law and public records; true stories of excess corruption in the ethics world; navigating Florida public records law, privacy, ethics and social media; complaints, misuse, anti-nepotism and voting; ethics during and after public service: conflicting contractual relationships & revolving door restrictions; gifts bribes, honoraria, and expenditures. The cost for this seminar is \$280. Completing this entire seminar will meet your ethics training requirement. Those Supervisors or Officers who are members of the Florida Bar may wish to purchase this option as Continuing Legal Education Credits can be earned.

We will notify you directly or through the District Manager’s office if and when other training opportunities become available.

Form 1 or Form 6

Section 8, Article II of the Florida Constitution requires constitutional officers and certain elected public officials to file a Form 6. In the last session, the legislature expanded the requirements to include *elected members of municipalities*. Independent special district officials remain exempt from the requirement to file a Form 6. Elected and appointed commissioners of community redevelopment agencies and local officers of independent special districts (including community development districts) are required to file Form 1.

For this year’s filing requirement, a completed Form 1 must be submitted prior to July 1, 2024 using the Electronic Filing System of the Florida Commission on Ethics, which can be accessed via the link at [Login - Electronic Financial Disclosure Management System \(floridaethics.gov\)](https://floridathics.com). You will no longer be able to file your completed Form 1 through your local Supervisor of Elections office.

If you have any questions or need additional information about ethics training requirements or financial disclosure, please do not hesitate to contact our office.

STONEGATE
COMMUNITY DEVELOPMENT DISTRICT

STAFF
REPORTS D

STONEGATE COMMUNITY DEVELOPMENT DISTRICT

BOARD OF SUPERVISORS FISCAL YEAR 2023/2024 MEETING SCHEDULE

LOCATION

Malibu Bay Clubhouse, 1020 NE 34th Avenue, Homestead, Florida 33033

DATE	POTENTIAL DISCUSSION/FOCUS	TIME
October 3, 2023 CANCELED	Regular Meeting	6:30 PM
November 7, 2023 CANCELED	Regular Meeting	6:30 PM
December 5, 2023 CANCELED	Regular Meeting	6:30 PM
February 6, 2024	Regular Meeting	6:30 PM
March 5, 2024	Regular Meeting	6:30 PM
April 2, 2024	Regular Meeting	6:30 PM
May 7, 2024	Regular Meeting	6:30 PM
June 4, 2024	Regular Meeting	6:30 PM
July 2, 2024	Regular Meeting	6:30 PM
August 6, 2024	Regular Meeting	6:30 PM
September 3, 2024	Regular Meeting	6:30 PM